



E-SMART THERMOSTAT W960

QUICK INSTALLATION GUIDE



(with TSTAT default profile ver.)

Important safety instructions

The applied nameplate is located at the bottom or rear of the product.

When using your thermostat equipment, basic safety precautions should always be followed to reduce the risk of fire, electric shock and injury, including the following:

1. This product should be installed by a qualified technician.
2. Read and understand all instructions.
3. Follow all warnings and instructions marked on the product.
4. Do not use liquid or aerosol cleaners. Use a damp cloth for cleaning.
5. Do not install this product near water such as near a bathtub, washbowl, kitchen sink, laundry tub or swimming pool, or in a wet basement or display.
6. Do not install this product on an unstable surface.
7. This product should not be installed near or over a radiator or heat register, or in any area where proper ventilation is not provided.
8. This product should be operated only from the type of power source indicated on the marking label.
9. Never spill liquid of any kind on the product.
10. To reduce the risk of electric shock, do not disassemble this product, but take it to an authorized service facility. Opening or removing parts of the thermostat or controller may expose you to dangerous voltages or other risks. Incorrect reassembling can cause electric shock when the product is subsequently used.
11. Dismount this product from the wall and refer servicing to an authorized service facility under the following conditions:
 - a. If liquid has spilled onto the product.
 - b. If the product has exposed to rain or water.
 - c. If the product does not operate normally by following the operating instructions. Adjust only those controls covered by the operation instructions. Improper adjustment of other controls may result in damage and often requires extensive work by an authorized technician to restore the product to normal operation.
 - d. If the product has been dropped and the thermostat and/or controller has been damaged.
 - e. If the product exhibits a distinct change in performance.
12. Avoid using the thermostat during an electrical storm. There is a remote risk of electric shock from lightning.
13. Do not use the thermostat to report a gas leak in the vicinity of the leak. This is a common event associated with the closing of any electrical circuit. The user should not plug the power cable, if the thermostat is located in an environment containing concentrations of flammable or flame-supporting gases, unless there is adequate ventilation. A spark in such an environment could create a fire or explosion. Such environments might include medical use of oxygen without adequate ventilation; industrial gases (cleaning solvents; gasoline vapor; etc.); a leak of natural gas; etc.
14. The power adapter is intended to be correctly oriented in a vertical or floor mount position. The prongs are not designed to hold the plug in place if it is plugged into a ceiling, under-the-table or cabinet outlet.
15. For pluggable equipment, the socket-outlet (power adaptor) shall be installed near the equipment and shall be easily accessible.
16. Use USB Type-C cable and batteries only as indicated in this user guide. Do not dispose of batteries in a fire. They may explode. Check with local codes for possible special disposal instructions.
17. There may be a risk of explosion if a wrong type of battery is used. Use only the supplied battery or replacement battery (AAA alkaline batteries x4). Dispose of used batteries according to the instructions.
18. The thermostat should be mounted at a height of less than 2 metres.

   CAUTION:

Keep small metallic objects such as pins and staples away from the thermostat.

SAVE THESE INSTRUCTIONS

Instructions de sécurité importantes

La plaque signalétique appliquée est située au bas et à l'arrière de la base du produit.

Lorsque vous utilisez votre équipement téléphonique, des précautions de base doivent toujours être prises pour réduire les risques d'incendie, d'électrocution et de blessure, notamment les suivantes:

1. Ce produit doit être installé par un technicien qualifié.
2. Lire et comprendre toutes les instructions.
3. Respecter tous les avertissements et instructions figurant sur le produit.
4. N'utilisez pas de nettoyeurs liquides ou en aérosol. Utilisez un chiffon humide pour le nettoyage.
5. N'utilisez pas ce produit près de l'eau, par exemple près d'une baignoire, d'une cuvette de lavage, d'un évier de cuisine, d'une cuve de lavage ou d'une piscine, ou dans un sous-sol ou une douche humide.
6. N'installez pas ce produit sur une surface instable.
7. Ce produit ne doit pas être installé à proximité ou au-dessus d'un radiateur ou d'un registre de chaleur, ou dans une zone où une ventilation adéquate n'est pas assurée.
8. Ce produit ne doit être utilisé qu'avec le type de source d'énergie indiqué sur l'étiquette de marquage.
9. Ne jamais renverser de liquide de quelque nature que ce soit sur le produit.
10. Pour réduire le risque d'électrocution, ne démontez pas ce produit, mais confiez-le à un service de réparation agréé. Ouvrir ou retirer des pièces du thermostat ou du contrôleur peut vous exposer à des tensions dangereuses ou à d'autres risques. Un remontage incorrect peut provoquer une électrocution lors de l'utilisation ultérieure du produit.
11. Démontez ce produit du mur et confiez la réparation à un centre de service agréé dans les conditions suivantes :
 - a. Si du liquide s'est répandu sur le produit.
 - b. Si le produit a été exposé à la pluie ou à l'eau.
 - c. Si le produit ne fonctionne pas normalement en suivant les instructions d'utilisation. Ne réglez que les commandes couvertes par les instructions d'utilisation. Le réglage incorrect d'autres commandes peut entraîner des dommages et nécessite souvent une intervention importante d'un technicien agréé pour rétablir le fonctionnement normal du produit.
 - d. Si le produit est tombé et que le thermostat et/ou le contrôleur ont été endommagés.
 - e. Si le produit présente un changement distinct de performance.
12. Évitez d'utiliser le thermostat pendant un orage. Il existe un faible risque d'électrocution dû à la foudre.
13. N'utilisez pas le thermostat pour signaler une fuite de gaz à proximité de la fuite. Il s'agit d'un événement courant associé à la fermeture de tout circuit électrique. L'utilisateur ne doit pas brancher le câble d'alimentation, si le thermostat est situé dans un environnement contenant des concentrations de gaz inflammable ou de flamme supportant le gaz, à moins qu'il y ait une ventilation adéquate. Une étincelle dans un tel environnement pourrait créer un incendie ou une explosion. De tels environnements pourraient inclure l'utilisation médicale d'oxygène sans ventilation adéquate; des gaz industriels (solvants de nettoyage; vapeur d'essence; etc.); une fuite de gaz naturel; etc.
14. Les adaptateurs d'alimentation sont destinés à être correctement orientés en position verticale ou au sol. Les broches ne sont pas conçues pour maintenir la fiche en place si elle est branchée au plafond, sous la table ou dans une prise de courant d'armoire.
15. Pour les équipements enfichables, la prise de courant (adaptateur électrique) doit être installée à proximité de l'équipement et doit être facilement accessible.
16. Utilisez le câble USB de type C et les piles uniquement comme indiqué dans ce guide d'utilisation. Ne jetez pas les piles au feu. Elles risquent d'exploser. Vérifiez les codes locaux pour connaître les éventuelles instructions spéciales d'élimination.
17. Il peut y avoir un risque d'explosion si un mauvais type de pile est utilisé. Utilisez uniquement la pile fournie ou une pile de rechange (4 piles alcalines AAA). Mettez les piles usagées au rebut conformément aux instructions.
18. Le thermostat doit être installé à une hauteur inférieure à 2 mètres.

   Mise en garde

Tenez les petits objets métalliques tels que les épingles et les agrafes à l'écart du thermostat.

CONSERVEZ CES INSTRUCTIONS

Other Safety Instructions

1. high or low extreme temperatures that a **battery** can be subjected to during use, storage or transportation; and
2. low air pressure at high altitude.
3. replacement of a **battery** with a n incorrect type that can defeat a **safeguard** (for example, in the case of some lithium **battery** types);
4. disposal of a **battery** into fire or a hot oven, or mechanically crushing or cutting of a **battery**, that can result in an **explosion**;
5. leaving a **battery** in an extremely high temperature surrounding environment that can result in an **explosion** or the leakage of flammable liquid or gas; and
6. a **battery** subjected to extremely low air pressure that may result in an **explosion** or the leakage of flammable liquid or gas.

The product network is installed wholly within the same building structure and not directly across the building.

For pluggable equipment, the socket-outlet (power adapter) shall be installed near the equipment and shall be easily accessible.

Autres instructions de sécurité

1. les températures extrêmes, hautes ou basses, auxquelles une pile peut être soumise pendant son utilisation, son stockage ou son transport; et
2. Une faible pression atmosphérique en haute altitude.
3. le remplacement d'une pile par un type incorrect qui peut neutraliser une protection (par exemple, dans le cas de certains types de piles au lithium);
4. L'élimination d'une pile au feu ou dans un four chaud, ou l'écrasement ou le découpage mécanique d'une pile, qui peut entraîner une explosion;
5. Le fait de laisser une pile dans un environnement à température extrêmement élevée, ce qui peut entraîner une explosion ou une fuite de liquide ou de gaz inflammable; et
6. Une pile soumise à une pression d'air extrêmement basse qui peut entraîner une explosion ou une fuite de liquide ou de gaz inflammable.

Le réseau de produits est installé entièrement dans la même structure de bâtiment et non directement à travers le bâtiment.

Pour les équipements enfichables, la prise de courant (adaptateur électrique) doit être installée à proximité de l'équipement et doit être facilement accessible.



Table of Contents

In the Box	05
Buttons & Indicators	06
Specifications	08
Installation Guide	10
• What You Must Know Before Installation	10
• Mounting	11
• Battery Installation	11
• Thermostat Mounting	11
• Controller Mounting	12
• Controller Wiring	12
• Wiring Diagrams	14
• Controller LED Indicator	15
Setup Guide	16
Thermostat Setup and Configuration	16
• Method 1 : Advanced Configuration Via App (Adv. Config via App)	16
• Method 2: Standard Configuration Via Thermostat (Std. Config via TSTAT)	17
• If select the "Conventional system"... ..	18
• If select the "Heat Pump System"... ..	20
Set Time	23
Set Date Time	24
Registration--Pairing Controller with Thermostat	26
Registration--Unpairing Controller with Thermostat	29
Maintenance	31
Support	32

1. In the Box



Thermostat display unit

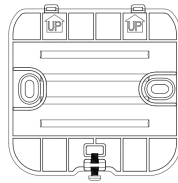

Wall plate

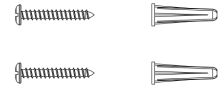

Wall mount screws & Anchors



AAA alkaline batteries x 4

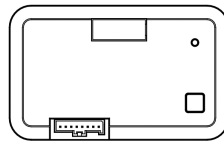

Controller



Wire harness

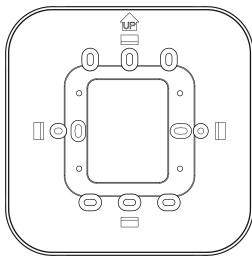

Universal deco plate

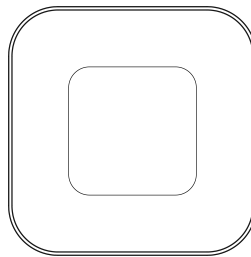

Deco plate cover

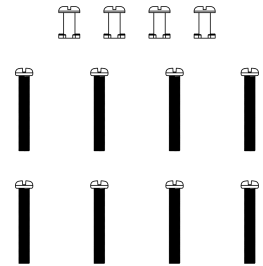

T locks & junction box screws

Needed But Not Supplied: :



USB-C Cable

- Dependent on your Android device's connection
- With USB-C connectors on both ends
- Ideal for syncing, and transferring data between USB-C devices



Micro-USB/USB-C Adapter

- Dependent on your Android device's connection
- Support OTG function
- Convert Micro-USB to Type-C



Android Smartphone/Tablet

- Android 8.0 or higher

2. Buttons & Indicators

Thermostat

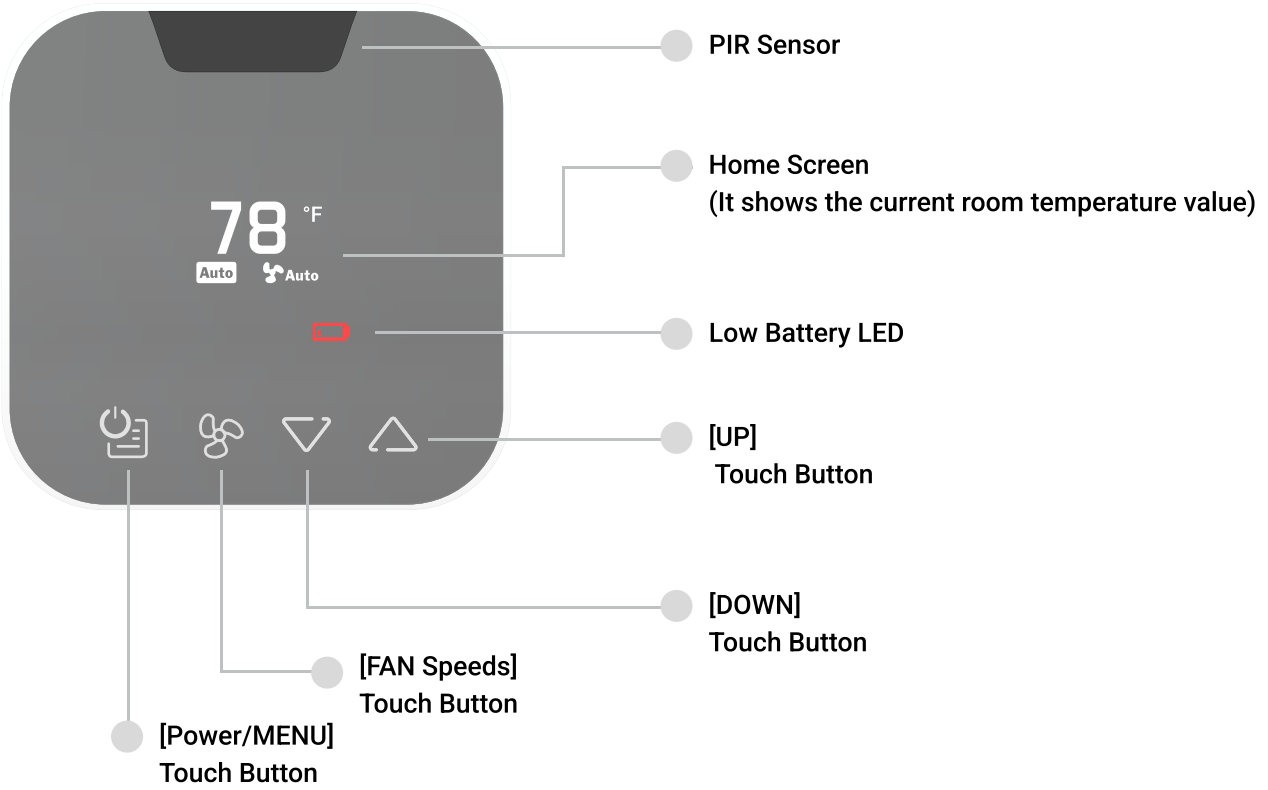

Controller

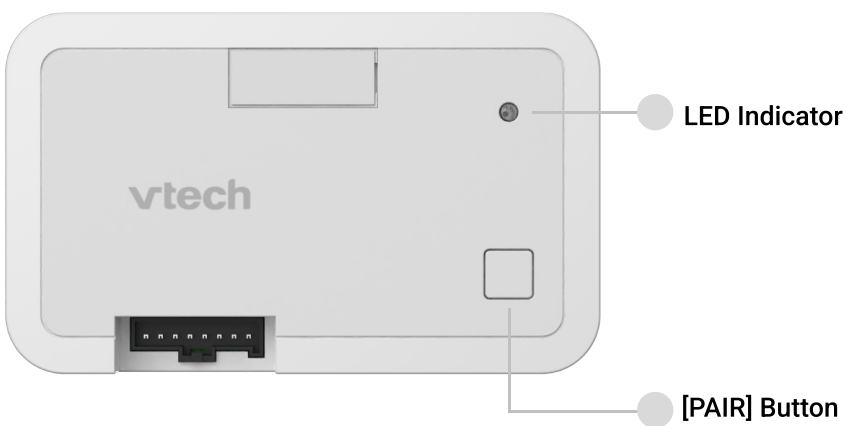

2. Boutons et voyants

Thermostat

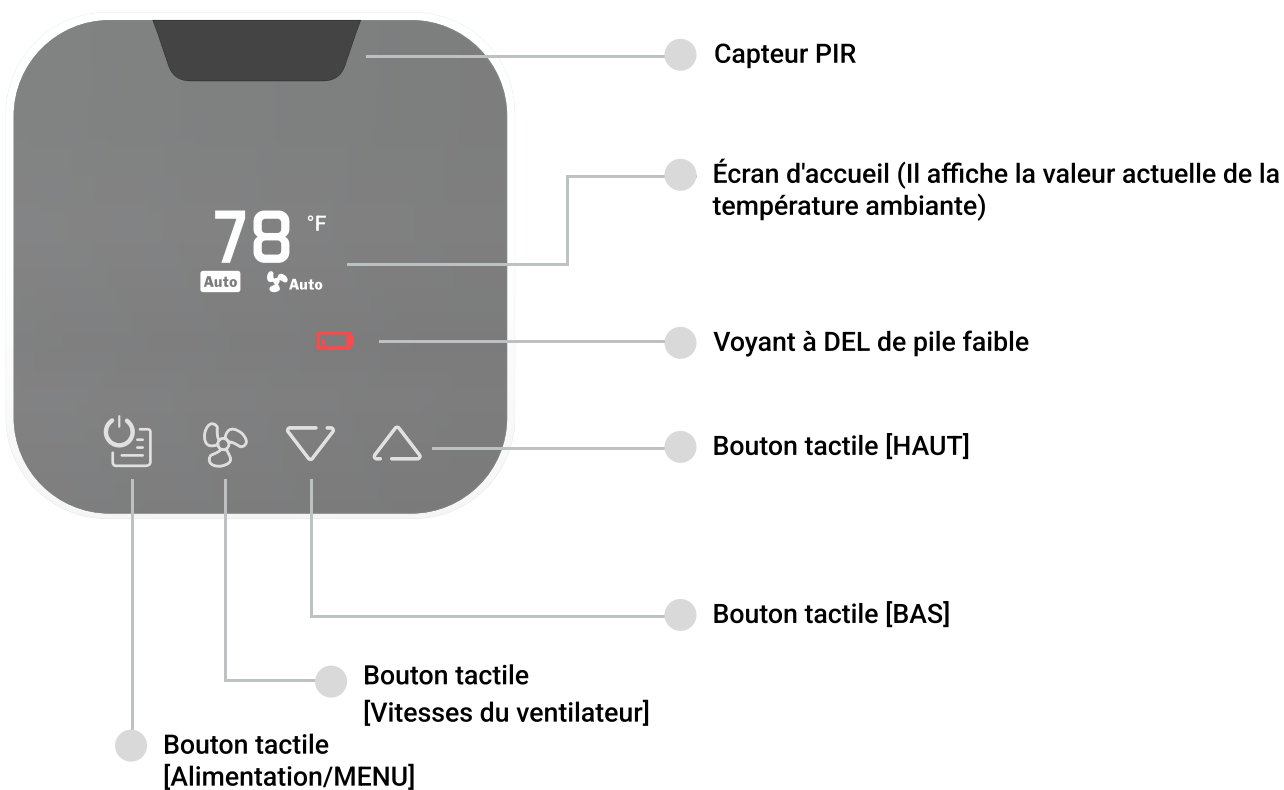

Contrôleur

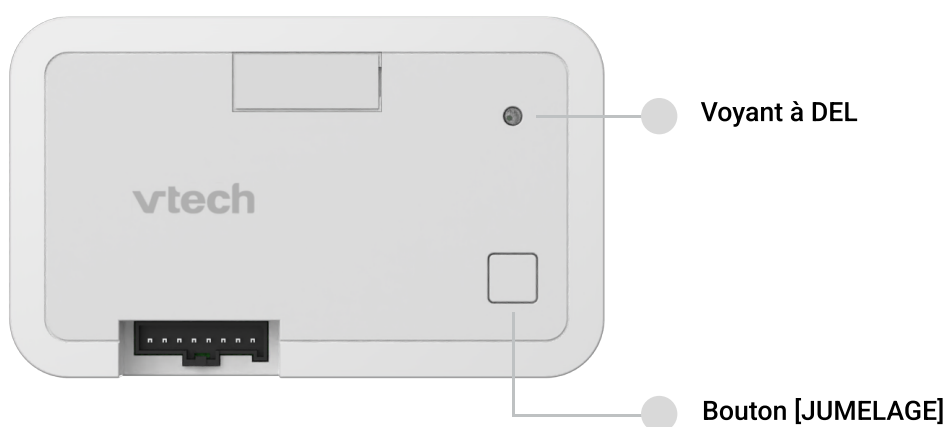

3. Specifications

	THERMOSTAT	CONTROLLER
Product Dimensions:	3.4" x 3.4" x 0.9" (8.6cm x 8.6cm x 2.3cm)	3.9" x 2.4" x 1" (10cm x 6.0cm x 2.4cm)
Mounting Type:	Surface mount	Double sided tape
HVAC System:	PTAC/VTAC/HEAT PUMP	PTAC/VTAC/HEAT PUMP
Power Requirements :	Alkaline Batteries (4x AAA)	Input 24V AC ~50/60Hz 0.5A with "C" common wire
Recommended Wire:	/	24 Gauge
Display:	1.3 inch (128 x 64) OLED	/
No of Keys:	4 Touch Keys	1, Pair Button
LED indicator:	1, Red color	1, Dual color
Outputs:	/	Output 0.5A MAX @24V AC
Temperature Range:	33-99°F (+/-1°F) 1-37°C (+/-0.5°C)	/
Occupancy Sensing:	Maximum Detection Distance: 9 m Maximum Detection Angle: 120°	/
Diagnostic Connection:	USB-Type C	/
RF Interface:	Zigbee 3.0 Frequency Band: 2.4GHz	ZigBee 3.0, Frequency Band: 2.4GHZ
APP System:	Android 8.0 or higher	Android 8.0 or higher
Battery Life:	24 months	/
Approvals:	UL62368-1; FCC Part 15B; Part 15.247; Part 15.249	UL60730-1;UL60730-2-9; FCC Part 15B; Part 15.247; Part 15.249

*Other information on controller :

- Rated impulse voltage: 800V
- Disconnection Type: 1.B
- Pollution degree : 2
- Automation cycle: 50000

3. Spécifications

	THERMOSTAT	CONTRÔLEUR
Dimensions du produit :	3.4" x 3.4" x 0.9" (8.6cm x 8.6cm x 2.3cm)	3.9" x 2.4" x 1" (10cm x 6.0cm x 2.4cm)
Type de montage :	Montage en surface	Ruban adhésif double face
Système HVAC :	PTAC/VTAC/POMPE À CHALEUR	PTAC/VTAC/POMPE À CHALEUR
Alimentation électrique requise :	Piles alcalines (4 piles AAA)	Entrée 24V AC ~50/60Hz 0.5A avec fil commun "C".
Fil recommandé :	/	Jauge 24
Affichage :	1,3 pouces (128 x 64) OLED	/
Nombre de touches :	4 touches tactiles	1, Paire de bouton
Indicateur à DEL :	1, couleur rouge	1, Bicolore
Sorties :	/	Sortie 0,5 A MAX. @ 24 V CA
Plage de température :	33-99°F (+/-1°F) 1-37°C (+/-0.5°C)	/
Détection de l'occupation :	Distance maximale de détection : 9 m Angle maximal de détection : 120°	/
Connexion de diagnostic :	USB-type C	/
Interface RF :	ZigBee 3.0, Bande de fréquence : 2,4 GHZ	ZigBee 3.0, Bande de fréquence : 2,4 GHZ
Système APP :	Android 8.0 ou supérieur	Android 8.0 ou supérieur
Durée de vie de la pile :	24 mois	/
Homologations :	UL62368-1; FCC article 15B; article 15.247; article 15,249 po	UL60730-1; UL60730-2-9; FCC article 15B; article 15.247; article 15,249 po

*Autres informations sur le contrôleur :

- Tension nominale d'impulsion : 800 V
- Degré de pollution : 2
- Type de déconnexion : 1.B
- Cycle d'automatisation : 50 000

4. What You Must Know Before Installation

- A trained, experienced technician must install this product.
- Carefully read these instructions. You could damage this product or cause a hazardous condition if you fail to follow these instructions.
- Please buy a USB Type-C cable for the configuration connection of the thermostat.
- High quality alkaline batteries for the thermostat are recommend.
- Electrical Hazard Caution: Failure to disconnect the power before beginning to install this product can cause electrical shock or equipment damage.
- Not to overtighten the screws during mounting.

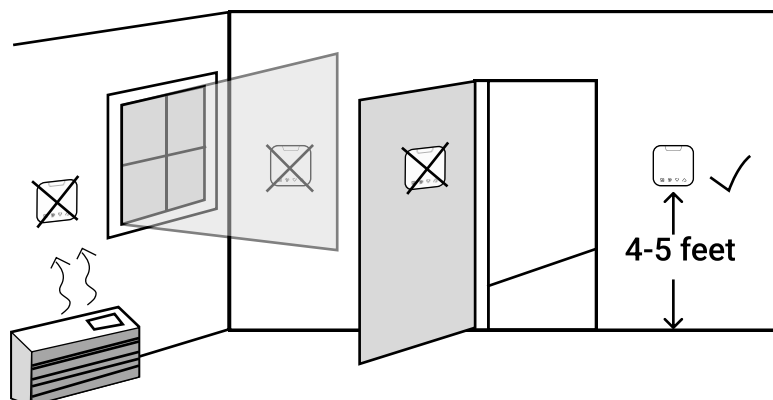

The thermostat should be mounted:

- Approximately 4 - 5 feet above the floor
- In a room with average temperature & humidity
- A location easy to access
- With good air circulation

The thermostat should not be mounted:

- In direct sunlight
- In areas that concealed chimneys or pipes might be found
- Where there are drafts or dead spots in corners and behind doors
- Close to or suffer from hot or cold air ducts
- On an outside wall behind the thermostat
- In areas that conditioning does not require

5. Mounting

Plate Mounting

Option 1: Direct Wall Mounting

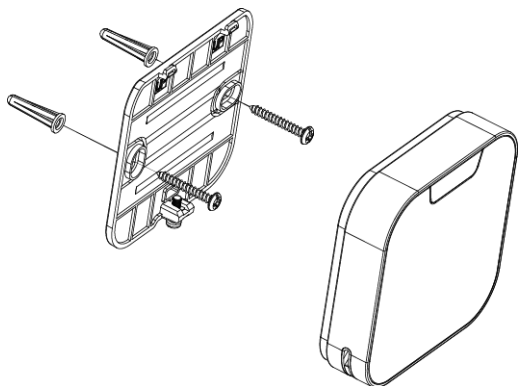

Option 2: Direct Wall Mounting with Deco Plate Kit

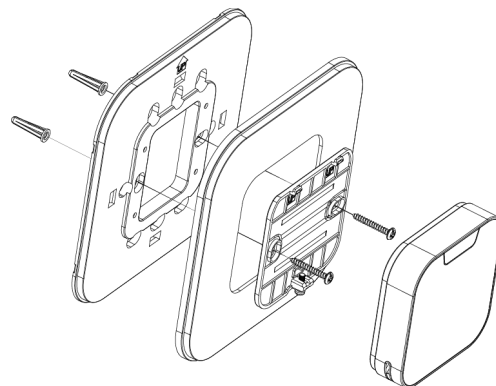

Option 3: Junction Box Mounting with Deco Plate Kit

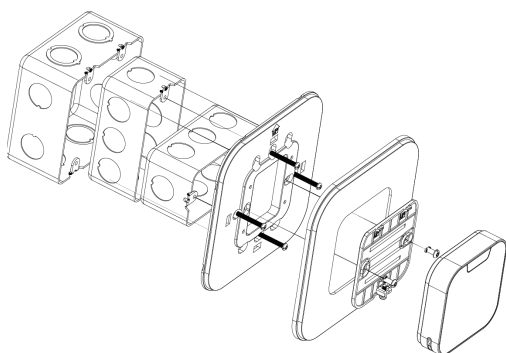

6. Battery Installation

Slide the four AAA alkaline batteries provided into the battery slots at the back of the thermostat.

7. Thermostat Mounting

Swing the thermostat into position by engaging the lugs on top of the wall plate before pushing it home carefully.

Lock up the thermostat on wall plate by tightening the captive screw underside.

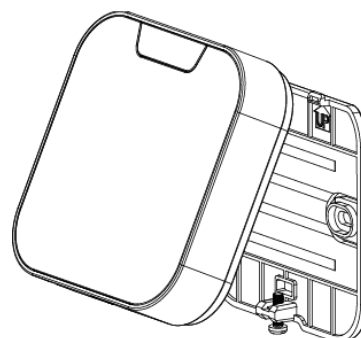

8. Controller Mounting

- Up to 200 feet away from the thermostat with no obstructions or walls in between, or up to 100 feet away with standard building materials in between.
- Mounted higher in a basement or further away from a large metal object.
- Pasted behind the front grille of PTAC with the double-sided tape at the backside.

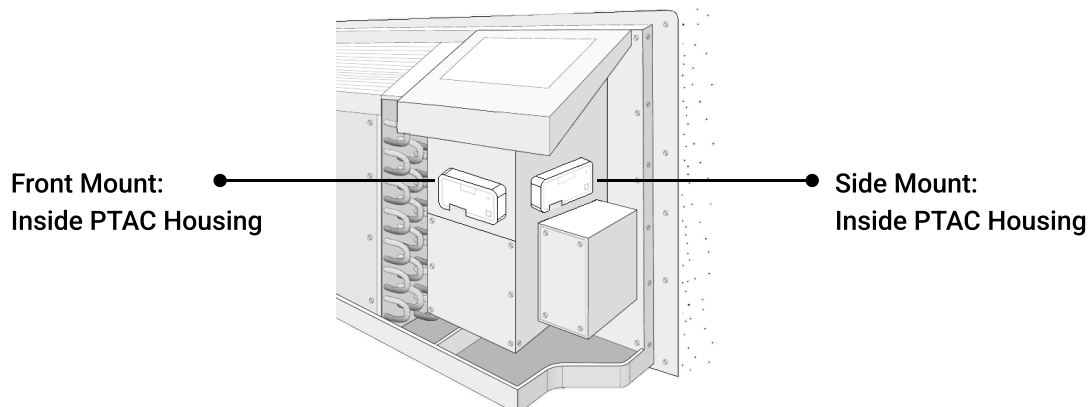

9. Controller Wiring

Connect the controller to the PTAC board terminals with the provided wires of different colours according to the table below.

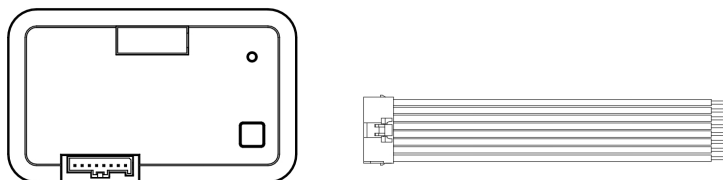

Wire Colour	Conventional System	Heat Pump System
Black	C 24VAC Common wire / 24V(N)	C 24VAC Common wire / 24V(N)
Red	R 24VAC Power / 24V(L)	R 24VAC Power / 24V(L)
Yellow	Y1 or W3 First stage of compressor relay/Third stage of heat relay	Y1 First stage of compressor relay
White	W1 First stage of heat relay/Aux heat relay	W1 or Y2 Aux heat/First stage of heat/Second stage of compressor relay
Orange	O/B or W2 Not used / Second stage of heat relay	O/B Changeover valve relay
Green	GH Fan relay, high	GH Fan relay, high
Purple	GL Fan relay, low	GL Fan relay, low
Brown	AUX Occupancy out	AUX or E Occupancy out / Emergency Heat

8. Fixation du contrôleur

- Jusqu'à 200 pieds de distance du thermostat sans obstruction ni mur entre les deux, ou jusqu'à 100 pieds de distance avec des matériaux de construction standard entre les deux.
- Installé plus haut dans un sous-sol ou plus loin d'un grand objet métallique.
- Collé derrière la grille avant du PTAC avec le ruban adhésif double face à l'arrière.

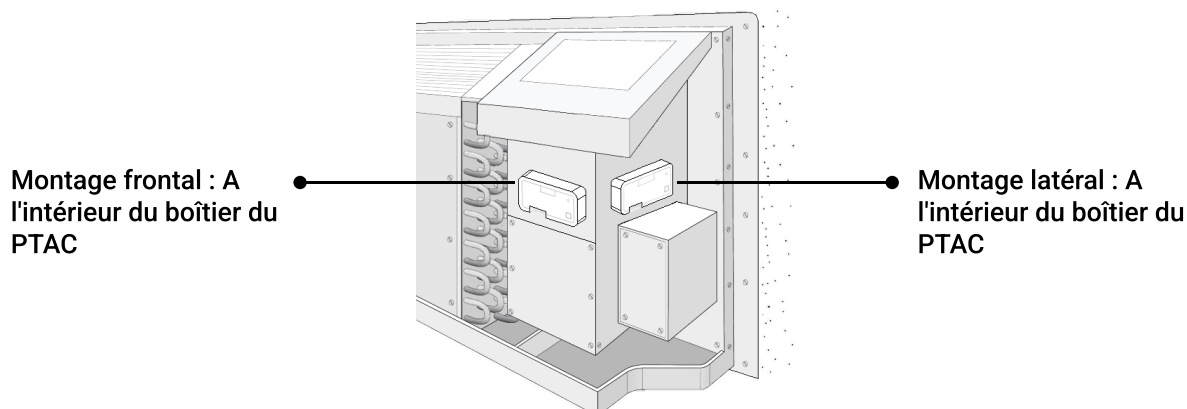

9. Filage du contrôleur

Connectez le contrôleur aux bornes de la carte PTAC avec les fils fournis de différentes couleurs, conformément au tableau ci-dessous.

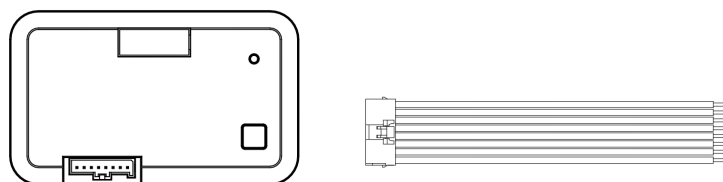

Couleur du filage	Système conventionnel		Système de thermopompe	
Noir	C	Fil commun de 24 V CA / 24V(N)	C	Fil commun de 24 V CA / 24V(N)
Rouge	R	Alimentation 24 V CA / 24V(L)	R	Alimentation 24 V CA / 24V(L)
Jaune	Y1 or W3	Premier étage du relais du compresseur/troisième étage du relais de chaleur	Y1	Premier étage du relais du compresseur
Blanc	W1	Premier étage du relais de chaleur/ Relais du chauffage auxiliaire	W1 or Y2	Relais du chauffage auxiliaire/ premier étage du chauffage/ second étage du compresseur
Orange	O/B or W2	Non utilisé / Deuxième étage du relais de chaleur	O/B	Relais de la vanne d'inversion
Vert	GH	Relais du ventilateur, haut	GH	Relais du ventilateur, bas
Violet	GL	Relais du ventilateur, bas	GL	Relais du ventilateur, bas
Brun	AUX	Sortie d'occupation	AUX or E	Sortie de l'occupant / Chauffage de secours

9.1 Wiring Diagrams

More details about the supported wiring diagrams?

Please read the manual: [Controller Wiring Set Up](#)



10. Controller LED Indicator

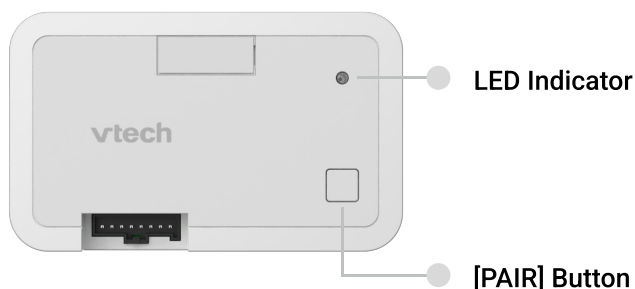

Dual Color LED	Condition	Annotation
Flash green	Start Zigbee pairing	<p>Press and hold [PAIR] for 5s (less than 10s), the controller indicator will turn to flash green, and when you release the button, will enter Zigbee pairing mode.</p> <p>During the process of Start Zigbee pairing (with the controller indicator is flash green), if user want to stop the pairing process, can press and hold [PAIR] for 5s.</p>
Solid green	Paired. Normal operation. The Controller is connected to thermostat operating normally.	/
Flash yellow	Removing all devices from system/ Factory reset.	When there is a paired device, press and hold 10s [PAIR] is to removing all connected devices.
Solid yellow	Not paired	<p>Situation 1: When it is powering up</p> <p>Situation2: If the controller is not paired with thermostat</p>
Flash green & red alternatively	Disconnected. The Controller is searching and trying to reconnect to thermostat.	After disconnecting thermostat, the controller keeps searching for the thermostat.
Solid red	Error	Any problems cause the HVAC or Controller not working.

11. Thermostat Setup and Configuration



Method 1:

Advanced Configuration Via App (Adv. Config via App)

1. Ready your thermostat to do configuration...

You will see the menu "System Setting" in the Engineering mode:

Enter "System Setting" by pressing  button.

You can always access the engineering mode by pressing and holding , , , for 10s.

Then select "System Configuration" by pressing  button.

Then select "Adv. Config via App" by pressing  button.

2. Start configuration with EC Tool...



How to use the EC Tool?

Please read the user manual: E-SMART Configuration Tool



11. Thermostat Setup and Configuration



Method 2:

Standard Configuration Via Thermostat (Std. Config via TSTAT)

You will see the menu "System Setting" in the Engineering mode:



Enter "System Setting" by pressing  button.

You can always access the engineering mode by pressing and holding , , , for 10s.



Then select "System Configuration" by pressing  button.



Then select "Std. Config via TSTAT" by pressing  button.



There are two wire systems, which are "Conventional system" and "Heat Pump System". Select one of the wire systems to be used in controller pressing  button.

If select the “Conventional system”...



1. Then choose the wiring diagram “1H1C, 2F” by pressing  button.



Remarks:

“1H1C, 2F” refers to the **manual: Controller Wiring Set Up , (Wiring Diagrams: Conventional Heating or Cooling Systems--15. Conventional 1 Stage Heating, 1 Stage cooling, 2 Fan Speed)**

2. Choose “Start Configuration” by pressing  button.

And the thermostat will display “Setting up ...” .



3. And then the thermostat will display “Setup Completed”.



4. Choose “Set Occupancy” by pressing  button.

And the thermostat will display “Set Date Time” .



5. Choose “Back” by pressing  button, return to menu “Std. Config via TSTAT”.



Back to menu
“Std. Config via TSTAT”

Technical Set up Table of Profile Setting for Conventional System--wiring diagram (1H1C, 2F)



Option	Default	
Compressor short cycle	ON	
Scale	F	
Room temp. calibration	0 °F	
1st Stage Differential (Heat)	0.5 °F	
1st Stage Differential (Cool)	0.5 °F	
Comfort setpoint	74 °F	
Auto mode deadband	6 °F	
Auto mode setpoint (Max)	80 °F	
Auto mode setpoint (Min)	65 °F	
Heating mode setpoint (Max)	80 °F	
Heating mode setpoint (Min)	65 °F	
Cooling mode setpoint (Max)	77 °F	
Cooling mode setpoint (Min)	64 °F	
Override mode	ON	
Override time out	30min(s)	
Protection setpoint	OFF	
Fan speed	2 speed	
Key tone	ON	
Confirmation tone	OFF	
Error tone	ON	
Reset tone	ON	
Sensor(PIR)	ON OFF	Select "set occupancy" and turn to "set date time" Select "Back"
Current PIN code on thermostat	0000	*The factory default Pin Code of thermostat is "0000". The user can amend the Pin Code with ECTool and it would update into system accordingly.
Reset PIN Code to thermostat	/	
Connect to DMS	OFF	

If select the “Heat Pump System”...



1. Then choose one of the wiring diagram by pressing button.



Remarks:
 “1HP AuxH, 2F” refers to the **manual: Controller Wiring Set Up , (Wiring Diagrams: Heat Pump Systems--7. Heat Pump system—1 stage Heat pump with Aux Heat, 2 Fan Speed)**



Remarks:
 “1HP, 2F” refers to the **manual: Controller Wiring Set Up , (Wiring Diagrams: Heat Pump Systems--3. Heat Pump system—1 stage Heat pump, 2 Fan Speed)**

2. Then choose either “Rev./4Way:Energize in Heat (B)” or “Rev./4Way:Energize in Cool (O)” by pressing button.

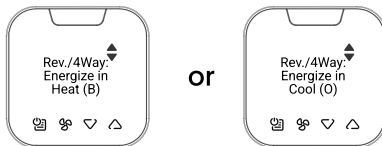

3. Choose “Start Configuration” by pressing button.

And the thermostat will display “Setting up ...” .



4. And then the thermostat will display “Setup Completed”.



5. Choose “Set Occupancy” by pressing button.

And the thermostat will display “Set Date Time” .



6. Choose “Back” by pressing button, return to menu “Std. Config via TSTAT”.



Back to menu
 “Std. Config via TSTAT”

Technical Set up Table of Profile Setting for Heat Pump System--wiring diagram (1HP AuxH, 2F)



Option	Default	
Compressor short cycle	ON	
Scale	F	
Room temp. calibration	0 °F	
1st Stage Differential (Heat)	0.5 °F	
2nd Stage Differential (Heat)	2 °F	
1st Stage Differential (Cool)	0.5 °F	
Comfort setpoint	74°F	
Auto mode deadband	6 °F	
Auto mode setpoint (Max)	80 °F	
Auto mode setpoint (Min)	65 °F	
Heating mode setpoint (Max)	80 °F	
Heating mode setpoint (Min)	65 °F	
Cooling mode setpoint (Max)	77 °F	
Cooling mode setpoint (Min)	64 °F	
Override mode	ON	
Override time out	30min(s)	
Protection setpoint	OFF	
Fan speed	2 speed	
Key tone	ON	
Confirmation tone	OFF	
Error tone	ON	
Reset tone	ON	
Sensor(PIR)	ON OFF	Select "set occupancy" and turn to "set date time" Select "Back"
Current PIN code on thermostat	0000	*The factory default Pin Code of thermostat is "0000". The user can amend the Pin Code with ECTool and it would update into system accordingly.
Reset PIN code to thermostat	/	
Connect to DMS	OFF	

Technical Set up Table of Profile Setting for Heat Pump System--wiring diagram (1HP, 2F)

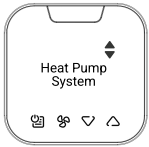





Option	Default	
Compressor short cycle	ON	
Scale	F	
Room temp. calibration	0 °F	
1st Stage Differential (Heat)	0.5 °F	
1st Stage Differential (Cool)	0.5 °F	
Comfort setpoint	74 °F	
Auto mode deadband	6 °F	
Auto mode setpoint (Max)	80 °F	
Auto mode setpoint (Min)	65 °F	
Heating mode setpoint (Max)	80 °F	
Heating mode setpoint (Min)	65 °F	
Cooling mode setpoint (Max)	77 °F	
Cooling mode setpoint (Min)	64 °F	
Override mode	ON	
Override time out	30min(s)	
Protection setpoint	OFF	
Fan speed	2 speed	
Key tone	ON	
Confirmation tone	OFF	
Error tone	ON	
Reset tone	ON	
Sensor(PIR)	OFF	Select "set occupancy" and turn to "set date time" Select "Back"
Current PIN code on thermostat	0000	*The factory default Pin Code of thermostat is "0000". The user can amend the Pin Code with ECTool and it would update into system accordingly.
Reset PIN code to thermostat	/	
Connect to DMS	OFF	

12. Set Time

You will see the menu "System Setting" in the Engineering mode:



Enter "System Setting" by pressing  button.

You can always access the engineering mode by pressing and holding , , , for 10s.



Then select "System Configuration" by pressing  button.



Then select "Other Setup" by pressing  button.



Then select "Date Time" by pressing  button.



Then select "Set Date Time" by pressing  button.

Remarks:

If your thermostat is configured by **Method 1: Advanced Configuration Via App**, can skip this part **12. Set Time**.

However, you can always set the time on thermostat through menu "Set Time" no matter the thermostat is configuring by **Method 1: Advanced Configuration Via App** or **Method 2: Standard Configuration Via Thermostat**

12. Set Date Time

After select "Set Date Time" by pressing  button...



1. Set "Year" by pressing  or  button .



Press  or  to change the year



Confirm by pressing 

2. Set "Month" by pressing  or  button .



Press  or  to change the month



Confirm by pressing 

3. Set "Day" by pressing  or  button .



Press  or  to change the day



Confirm by pressing 

4. Set the Time zone by pressing  or  button .



Press  or  to change the time zone



Press  or  to change the time zone



Press  or  to change the time zone



Confirm by pressing 

5. Set the Time (Hrs) by pressing  or  button .



Press  or  to adjust hours (digits 1-12)



Confirm by pressing 

6. Set the Time (Mins) by pressing  or  button .



Press  or  to adjust minutes (digits 0-59)



Confirm by pressing 

And the thermostat will display  , wait for 2s time out, will go to menu "Date Time".





13. Registration--Pairing Controller with Thermostat

1. Ready your thermostat to do registration...

You will see the menu "System Setting" in the Engineering mode:



You can always access the engineering mode by pressing and holding , , , for 10s.

Enter "System Setting" by pressing  button.



Then select "Registration" by pressing  button.



Then select "Register Device" by pressing  button.

If the thermostat displays "Connected" after selected the "Register Device" on menu:



You can skip this whole part: **12. Registration--Pairing Controller with Thermostat**

1. After select "Register Device" on menu, the thermostat will display "Tap [MENU] x3 to start pairing". So press  three times on the thermostat to start pairing an available controller.



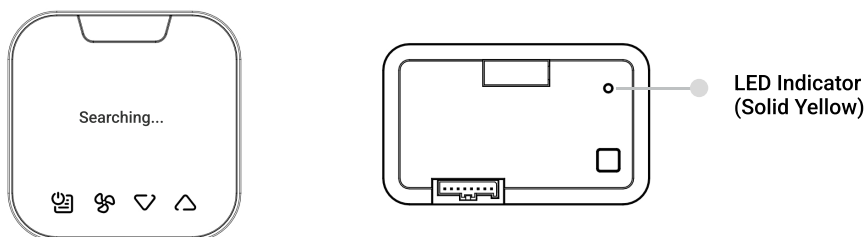

2. When the screen shows "Searching...", it means the thermostat will attempt to connect to a controller within range.

Upon power up, the controller LED indicator will begin **Solid Yellow** as it means there are no paired device.

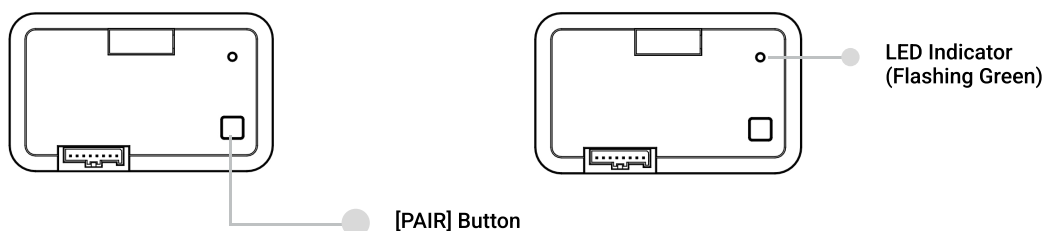

To pair controller with thermostat, press [PAIR] button for 5 seconds, then release the button to enter Zigbee pairing. The controller LED indicator will **begin flashing Green** while it waits for an available thermostat to join.



If you want to stop pairing process, you can press and hold  button for 3 seconds on the thermostat.

Once the thermostat has found and paired to controller, the thermostat will temporarily display "Connected" when it joins with a controller. Moreover, the paired controller's LED indicator will turn to **solid green** and its means the controller is connecting with the thermostat in a normal operation mode.

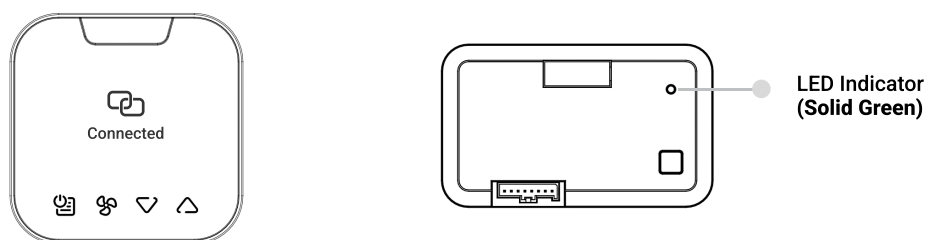

3. The thermostat will return to the menu "Register Device".

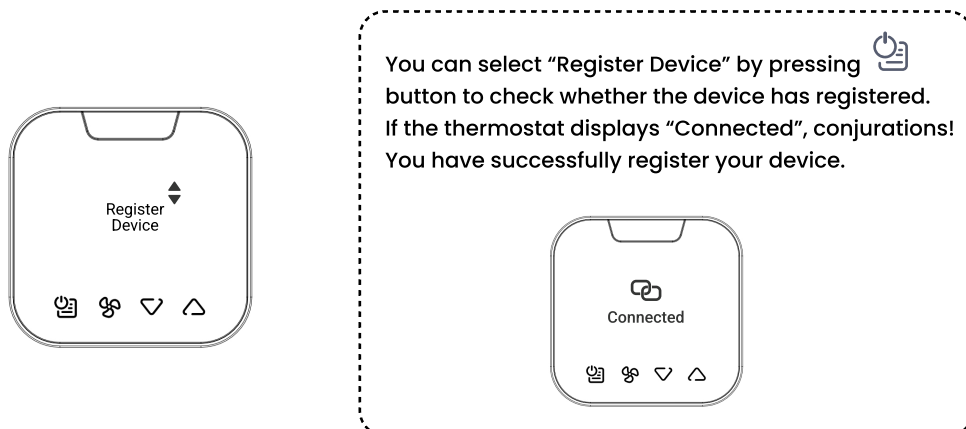

4. You may now select menu "Back" to go back.



Then select menu "Exit" to exit the Engineering Mode.

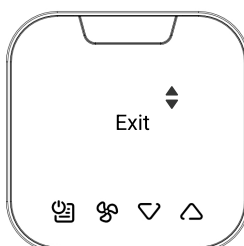

If you have done the configuration, (refer to **11. Thermostat Setup and Configuration**).

After select menu "Exit", you will exit the Engineering Mode.

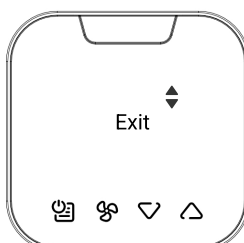

Remark:

If you have not yet done the any configuration before...

After select menu "Exit", you will enter the Engineering Mode again.

14. Registration--Unpairing Controller with Thermostat

Method 1:

All connected devices will be removed from this system

1. Press [PAIR] button for 10 seconds.

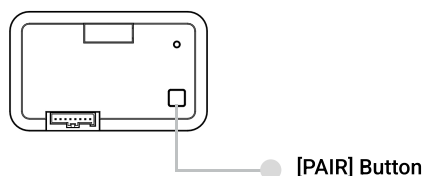

2. The Controller LED will begin flashing Yellow. Then all connected devices will be removed from this system.

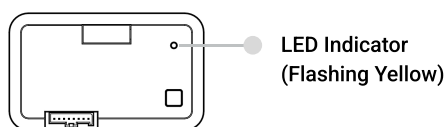

And the thermostat will display "Deregistered by controller" .



And then the thermostat will display "Pls register again". Press  button to confirm, and will go to menu "Registration".

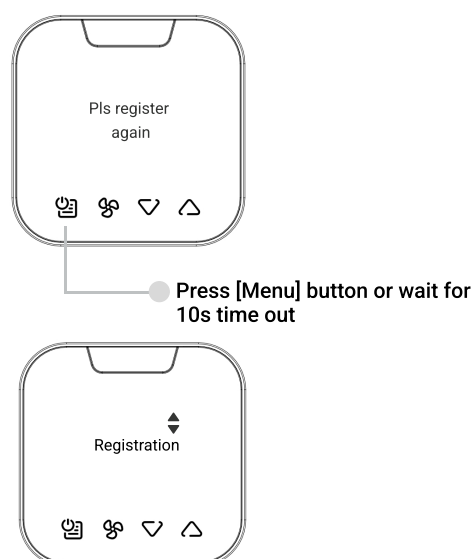

You can register the device through menu "Registration"

Method 2 :

To deregister the specific unit of thermostat

1. Enter Engineering mode menu by pressing and holding , ,  for 10s.

You will see the menu "System Setting" in the Engineering mode:



Enter "System Setting" by pressing  button.



Then select "Registration" by pressing  button.



Then select "Deregister Device" by pressing  button.

2. Confirm the deregister device on menu by pressing  . Then press  to confirm your selected device for deregistration



3. Once it confirmed to deregister the thermostat, it will display "{Serial number} is deregistered" and the thermostat is no longer be connected to a network.



Maintenance

Taking care of your thermostat

Your thermostat contains sophisticated electronic parts, so it must be treated with care.

Avoid rough treatment

Place the thermostat and handset down gently. Save the original packing materials to protect your thermostat if you ever need to ship it.

Avoid water

Your thermostat can be damaged if it gets wet. Do not use the thermostat outdoors in the rain, or handle it with wet hands. Do not install thermostat near a sink, bathtub or display.

Electrical storms

Electrical storms can sometimes cause power surges harmful to electronic equipment. For your own safety, take caution when using electrical appliances during storms.

Cleaning your thermostat

Your thermostat has a durable plastic casing that should retain its luster for many years. Clean it only with a soft cloth slightly dampened.



support@vtechhotelphones.com



Specifications are subject to change without notice.

Copyright © 2023

VTech Communications, Inc.

All rights reserved. 05/09.

W960_Installation_with TSTAT default profile_QSG_2023.05.09