

vtech®

 **ErisStation™**

DECT USB Expansion Speakerphone

VCS855

Quick Start Guide

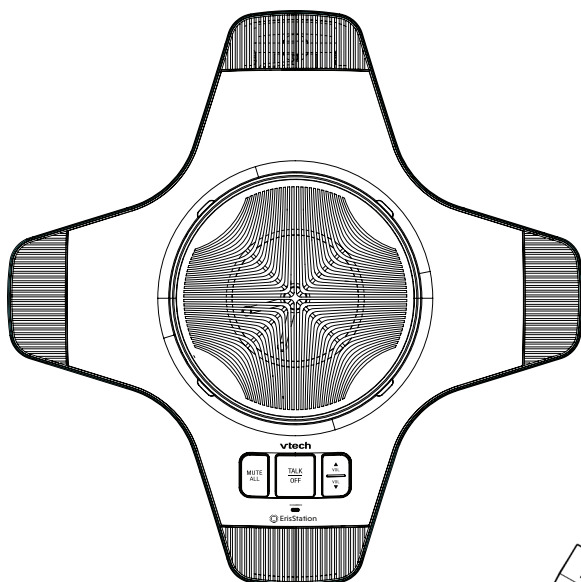

VCS855



VU-060



DECT 6.0

Important safety instructions

When using your telephone equipment, basic safety precautions should always be followed to reduce the risk of fire, electric shock and injury to persons, including the following:

Safety Information

1. Read and understand all instructions.
2. Follow all warnings and instructions marked on the product.
3. Unplug this product from the wall outlet before cleaning. Do not use liquid or aerosol cleaners. Use a damp cloth for cleaning.
4. Do not use this product near water such as near a bathtub, wash bowl, kitchen sink, laundry tub or swimming pool, or in a wet basement or shower.
5. Do not place this product on an unstable table, shelf, stand or other unstable surfaces.
6. Slots and openings in the wireless speaker are provided for ventilation. To protect them from overheating, these openings must not be blocked by placing the product on a soft surface such as a bed, sofa or rug. This product should never be placed near or over a radiator or heat register. This product should not be placed in any area where proper ventilation is not provided.
7. This product should be operated only from the type of power source indicated on the marking label. If you are not sure of the type of power supply in your office, consult your dealer or local power company.
8. Do not allow anything to rest on the power cord. Do not install this product where the cord may be walked on.
9. Never push objects of any kind into this product through the slots in the product because they may touch dangerous voltage points or create a short circuit. Never spill liquid of any kind on the product.
10. To reduce the risk of electric shock, do not disassemble this product, but take it to an authorized service facility. Opening or removing parts of the wireless speakerphone other than specified access doors may expose you to dangerous voltages or other risks. Incorrect reassembling can cause electric shock when the product is subsequently used.
11. Do not overload wall outlets and extension cords.
12. Unplug this product from the wall outlet and refer servicing to an authorized service facility under the following conditions:
 - When the power supply cord or plug is damaged or frayed.
 - If liquid has been spilled onto the product.
 - If the product has been exposed to rain or water.
 - If the product does not operate normally by following the operating instructions. Adjust only those controls that are covered by the operation

- instructions. Improper adjustment of other controls may result in damage and often requires extensive work by an authorized technician to restore the product to normal operation.
 - If the product has been dropped and the wireless speaker has been damaged.
 - If the product exhibits a distinct change in performance.
13. Avoid using the ErisStation wireless speaker during an electrical storm. There is a remote risk of electric shock from lightning.
 14. Do not use the ErisStation Wireless Speaker to report a gas leak in the vicinity of the leak. Under certain circumstances, a spark may be created when the adapter is plugged into the power outlet. This is a common event associated with the closing of any electrical circuit. The user should not plug the product into a power outlet if the product is located in an environment containing concentrations of flammable or flame-supporting gases, unless there is adequate ventilation. A spark in such an environment could create a fire or explosion. Such environments might include: medical use of oxygen without adequate ventilation; industrial gases (cleaning solvents; gasoline vapors; etc.); a leak of natural gas; etc.
 15. The power cables are intended to be correctly oriented in a vertical or floor mount position. The prongs are not designed to hold the plug in place if it is plugged into a ceiling or cabinet outlet.
 16. For pluggable equipment, the socket-outlet shall be installed near the equipment and shall be easily accessible.
 17.   CAUTION: Use only the batteries indicated in this manual. There may be a risk of explosion if a wrong type of battery is used. Use only the supplied rechargeable battery or replacement battery pack (BT260280). Do not dispose of batteries in a fire. They may explode. Dispose of used battery according to the information in The RBRC® seal.
 18. Use only the adapter included with this product. Incorrect adapter polarity or voltage can seriously damage the product. Base unit power adapter: Input 100–240V AC 50/60Hz; Output: 12V DC @ 1.0A.
 19. Use only with UL listed phones.

Precautions for users of implanted cardiac pacemakers

Cardiac pacemakers (applies only to digital cordless devices):

Wireless Technology Research, LLC (WTR), an independent research entity, led a multidisciplinary evaluation of the interference between portable digital cordless devices and implanted cardiac pacemakers. Supported by the U.S. Food and Drug Administration, WTR recommends to physicians that:

Pacemaker patients

- Should keep digital cordless devices at least six inches from the pacemaker.
- Should NOT place digital cordless devices directly over the pacemaker, such as in a breast pocket, when it is turned ON.
- Should use the digital cordless device at the ear opposite the pacemaker. WTR's evaluation did not identify any risk to bystanders with pacemakers from other persons using wireless telephones.

WTR's evaluation did not identify any risk to bystanders with pacemakers from other persons using digital cordless devices.

SAVE THESE INSTRUCTIONS

Congratulations

on purchasing your new VTech product. Before using this product, please read the “Important safety instructions” on page 2-4 of this manual.

This quick start guide provides you with the basic installation, setup, and operation instructions for your VTech product.

For customer service or product information, visit our website at vtechphones.com or call **1 (800) 595-9511**.



Telephones identified with this logo have reduced noise and interference when used with most T-coil equipped hearing aids and cochlear implants. The TIA-1083 Compliant Logo is a trademark of the Telecommunications Industry Association. Used under license.

For Dongle VU-060:

FCC ID: EW780-1391-00

IC: 1135B-80139100

HVIN: VU-060

PMN: DECT Dongle

For Speakerphone VCS855:

FCC ID: EW780-0585-00

IC: 1135B-80058500

HVIN: VCS855

PMN: VCS855

ErisStation® is a registered trademark of VTech Communications, Inc.

Orbitlink Wireless Technology™ is a trademark of VTech Communications, Inc.

Introduction

The VU-060 DECT Dongle is preregistered to the VCS855 Wireless speaker. The dongle enables you to connect the wireless speaker to your computer for playing music or audio from soft phone calls.

What's in the box

Your product package contains the following items. Save your sales receipt and original packaging in the event warranty service is necessary.

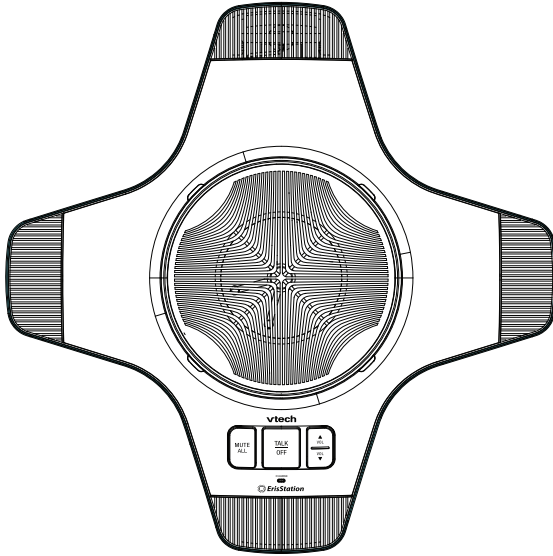
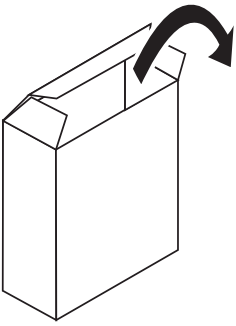

VCS855 Wireless Speaker



VU-060 DECT Dongle

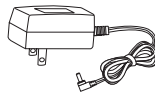

Power adapter

Quick
Start
Guide
VCS855

NOTE: The wireless speaker battery (BT260280) is not included, and must be purchased separately.

To purchase the battery, or any accessories or replacements, visit our website at www.vtechphones.com/store/products/accessories.

Wireless Speaker Overview

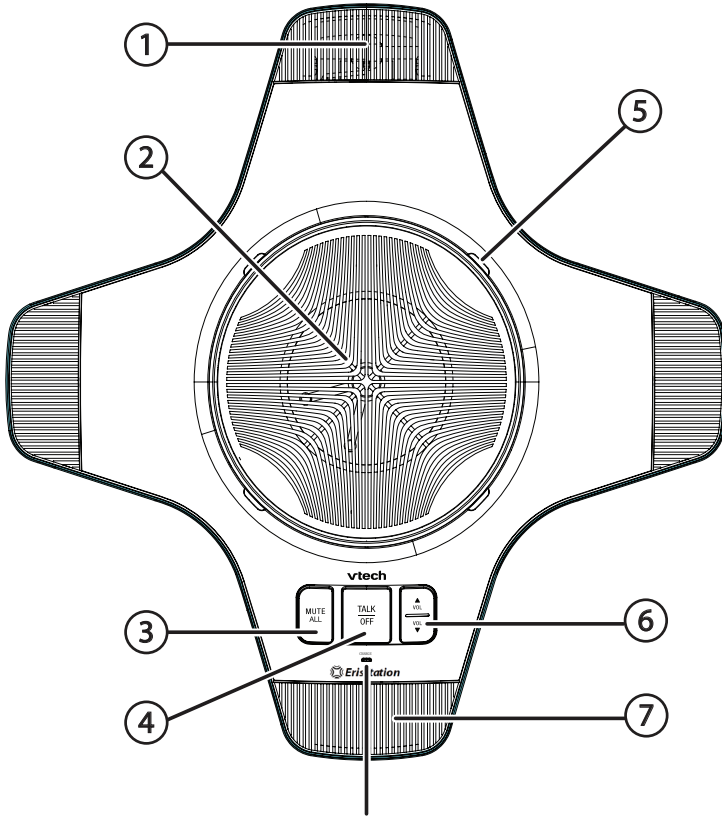

Change LED
- On when charging
- Off when charging is complete
- Flashes when battery is low

1. Microphone

2. Speaker

3. **MUTE ALL**

During a call, press to mute or end mute all microphones in the system.

TALK

4. **OFF**

- Press to enable the speaker.
- Press to answer or end a call.

5. Multipurpose LEDs (four)

▲ / VOL

6. VOL / ▼

- Press to adjust the speaker volume.
- Press to adjust the ringer volume.
- During a call, press to adjust the speaker volume.

7. Microphone

Wireless Speaker LEDs

LED color and behavior	Wireless speaker status
Steady Green	• Call active, speaker on
Flashes Green	• Incoming call
Flashes Green slowly	• Paged by base
Steady Green for five seconds	• Successfully registered
Flashes Red and Green alternately	• Ready for registration
Steady Red for five seconds	• Registration failed
Steady Red	• Microphone muted
Flashes Red slowly	• Out of range, deregistered
Steady Orange	• Reset mode
Steady Orange for five seconds	• Power on

Install the wireless speaker battery



- CAUTION: Risk of explosion! Batteries should not be exposed to excessive heat such as bright sunlight or fire.
- CAUTION: Risk of explosion if battery is replaced by an incorrect type. Dispose of used batteries according to the instructions.
- Use only battery model BT260280.

1. After removing the battery door, plug the battery connector securely into the socket inside the battery compartment.
2. Place the battery into the battery compartment.
3. Attach the battery door until it clicks into place.

Connect power to the wireless speaker

1. Plug one end of the AC adapter into the power jack on the bottom of the unit.
2. Route the cord through the slots.
3. Plug the large end of the AC adapter into a wall outlet not controlled by a switch.
 - The supplied power adapter is designed for use only with the VCS855 wireless speaker. It is not designed to power other devices. Do not connect the supplied power adapter to any other devices.
 - The AC power cord is intended for a vertical or floor mount position. The prongs are not designed to hold the plug in place if it is plugged into a ceiling, under-the-table, or cabinet outlet.

Wireless speaker specifications

Frequency control	Crystal controlled PLL synthesizer
Transmit frequency	1921.536–1928.448 MHz
Channels	5
Nominal effective range	Maximum power allowed by FCC and IC. Actual operating range may vary according to environmental conditions at the time of use.
Power requirements	Ni-MH Battery Pack (BT260280); 7.2V; 2100mAH rechargeable battery Power adapter: Input: 100–240V AC 50/60Hz Output: 12V DC @ 1.0A

DECT Dongle Overview

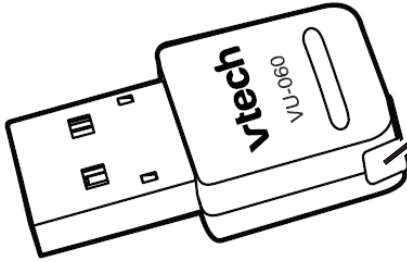

LED status button

For manually registering the dongle to a speaker.

NOTE: Your dongle is preregistered to the wireless speaker.

DECT Dongle LEDs

LED color and behavior	DECT dongle status
Steady Green	• Dongle is not in use
Steady Green for three seconds	• Dongle is deregistered from the wireless speaker
Flashes Green quickly	• Incoming call
Flashes Green quickly every three seconds	• Wireless speaker is in use
Steady Red	• Dongle is not registered
Flashes Red very quickly	• Dongle is registering to a wireless speaker
Flashes Red quickly	• Dongle is entering registration mode
Flashes Red slowly	• Wireless speaker is muted

Connecting the wireless speaker to a computer

Your DECT dongle is preregistered to the wireless speaker.

To connect the wireless speaker to your computer:

1. Plug the dongle in the USB port on your computer.
The dongle LED light will turn steady green.

TALK

2. Press the **OFF** key on the wireless speaker.
This enables the speaker to play audio.

Registering the dongle

Your DECT Dongle is preregistered to the wireless speaker. You do not need to register your dongle. However, the steps below are provided in the event you need to manually deregister and re-register your dongle.

To register the dongle to the wireless speaker:

1. Make sure the wireless speakerphone is properly installed. Flashing red and green LEDs indicate the wireless speaker is ready for registration.
2. Press and hold the REGISTRATION button on the bottom of the wireless speaker for five seconds, and then release the button.
3. Plug the dongle to the computer.
4. Press and hold the LED status button on the dongle for about four seconds until the Dongle LED light flashes red very quickly, and then release the button.

It takes about 60 seconds to complete the registration process. Once the wireless speaker is registered, the wireless speaker LEDs stop flashing. The LEDs turn green briefly and then turn off.

Deregistering the dongle

1. Press the key on the dongle for 10 seconds to enter deregistration mode. After 4 seconds the red LED starts to double-flash; after 10 seconds the LED starts to flash red rapidly, indicating that the dongle has entered deregistration mode.
2. Release the key and press it again for 1 second to confirm deregistration. The LED turns green for three seconds, turns off for one second and then shows steady red light.

Maintenance

Taking care of your wireless speakerphone and DECT dongle

- Your wireless speakerphone / DECT dongle contains sophisticated electronic parts, so it must be treated with care.

Avoid rough treatment

- Place the DECT dongle down gently.
- Save the original packing materials to protect your wireless speakerphone / DECT dongle if you ever need to ship it.

Avoid water and heat

- Your wireless speakerphone / DECT dongle can be damaged if it gets wet.
- Do not use the wireless speakerphone / DECT dongle outdoors in the rain, or handle it with wet hands.
- Do not install the speakerphone charger near a sink, bathtub or shower.
- Do not expose the product to extreme heat.

Electrical storms

- Electrical storms can sometimes cause power surges harmful to electronic equipment.
- For your own safety, take caution when using electrical appliances during storms.

Cleaning your wireless speakerphone / DECT dongle

- Your wireless speakerphone / DECT dongle has a durable plastic casing that should retain its luster for many years.
- Clean it only with a soft cloth slightly dampened with water or mild soap.
- Do not use excess water or cleaning solvents of any kind.

Compliance

FCC part 15

This equipment has been tested and found to comply with the requirements for a Class B digital device under Part 15 of the Federal Communications Commission (FCC) rules.

These requirements are intended to provide reasonable protection against harmful interference in a residential installation. This equipment generates, uses and can radiate radio frequency energy and, if not installed and used in accordance with the instructions, may cause harmful interference to radio communications. However, there is no guarantee that interference will not occur in a particular installation.

If this equipment does cause harmful interference to radio or television reception, which can be determined by turning the equipment off and on, the user is encouraged to try to correct the interference by one or more of the following measures:

- Reorient or relocate the receiving antenna.
- Increase the separation between the equipment and receiver.
- Connect the equipment into an outlet on a circuit different from that to which the receiver is connected.
- Consult the dealer or an experienced radio/TV technician for help.

Changes or modifications to this equipment not expressly approved by the party responsible for compliance could void the user's authority to operate the equipment.

This device complies with Part 15 of the FCC Rules. Operation is subject to the following two conditions: (1) this device may not cause interference, and (2) this device must accept any interference, including interference that may cause undesired operation.

Privacy of communications may not be ensured when using this equipment.

To ensure safety of users, the FCC has established criteria for the amount of radio frequency energy that can be safely absorbed by a user or bystander according to the intended usage of the product. This product has been tested and found to comply with the FCC criteria. The wireless speaker shall be installed and used such that parts of the user's body other than the hands are maintained at a distance of approximately 20 cm (8 inches) or more.

Limited warranty

1. What does this limited warranty cover?

VTech of this VTech product warrants to the holder of a valid proof of purchase (“CONSUMER” or “you”) that the product and all accessories provided in the sales package (“PRODUCT”) are free from defects in material and workmanship, pursuant to the following terms and conditions, when installed and used normally and in accordance with the PRODUCT operating instructions. This limited warranty extends only to the CONSUMER for products purchased and used in the United States of America.

2. What will be done if the PRODUCT is not free from defects in materials and workmanship during the limited warranty period (“materially defective PRODUCT”)?

During the limited warranty period, VTech’s authorized service representative will repair or replace at VTech’s option, without charge, a materially defective PRODUCT. If VTech repairs the PRODUCT, they may use new or refurbished replacement parts. If VTech chooses to replace the PRODUCT, they may replace it with a new or refurbished PRODUCT of the same or similar design. VTech will retain defective parts, modules, or equipment. Repair or replacement of the PRODUCT, at VTech’s option, is your exclusive remedy. VTech will return repaired or replacement products to you in working condition. You should expect the repair or replacement to take approximately 30 days.

3. How long is the limited warranty period?

The limited warranty period for the PRODUCT extends for TWO (2) YEARS from the date of purchase. If VTech repairs or replaces a materially defective PRODUCT under the terms of this limited warranty, this limited warranty also applies to repaired or replacement PRODUCT for a period of either (a) 90 days from the date the repaired or replacement PRODUCT is shipped to you or, (b) the time remaining on the original two-year limited warranty; whichever is longer.

4. What is not covered by this limited warranty?

This limited warranty does not cover:

- PRODUCT that has been subjected to misuse, accident, shipping or other physical damage, improper installation, abnormal operation or handling, neglect, inundation, fire, water, or other liquid intrusion; or
- PRODUCT that has been damaged due to repair, alteration, or modification by anyone other than an authorized service representative of VTech; or
- PRODUCT to the extent that the problem experienced is caused by signal conditions, network reliability or cable or antenna systems; or
- PRODUCT to the extent that the problem is caused by use with non-VTech accessories; or

- PRODUCT whose warranty/quality stickers, PRODUCT serial number plates or electronic serial numbers have been removed, altered or rendered illegible; or
- PRODUCT purchased, used, serviced, or shipped for repair from outside the United States of America, or used for commercial or institutional purposes (including but not limited to products used for rental purposes); or
- PRODUCT returned without a valid proof of purchase (see item 6 below); -or-
- Charges for installation or setup, adjustment of customer controls, and installation or repair of systems outside the unit.

5. How do you get warranty service?

To obtain warranty service in the United States of America, visit

vtechphones.com or call **1 (800) 595-9511**.

NOTE: Before calling for service, please review the user's manual; a check of the PRODUCT's controls and features may save you a service call.

Except as provided by applicable law, you assume the risk of loss or damage during transit and transportation and are responsible for delivery or handling charges incurred in the transport of the PRODUCT(s) to the service location. VTech will return repaired or replaced PRODUCT under this limited warranty to you. Transportation, delivery or handling charges are prepaid. VTech assumes no risk for damage or loss of the PRODUCT in transit. If the PRODUCT failure is not covered by this limited warranty, or proof of purchase does not meet the terms of this limited warranty, VTech will notify you and will request that you authorize the cost of repair prior to any further repair activity. You must pay for the cost of repair and return shipping costs for the repair of products that are not covered by this limited warranty.

6. What must you return with the PRODUCT to get warranty service?

You must:

- a. Return the entire original package and contents including the PRODUCT to the VTech service location along with a description of the malfunction or difficulty; and
- b. Include a "valid proof of purchase" (sales receipt) identifying the PRODUCT purchased (PRODUCT model) and the date of purchase or receipt; and
- c. Provide your name, complete and correct mailing address, and telephone number.

7. Other limitations

This warranty is the complete and exclusive agreement between you and VTech of this PRODUCT. It supersedes all other written or oral communications related

to this PRODUCT.

VTech provides no other warranties for this PRODUCT. The warranty exclusively describes all of VTech's responsibilities regarding the PRODUCT. There are no other express warranties. No one is authorized to make modifications to this limited warranty and you should not rely on any such modification.

State/Provincial Law rights: This warranty gives you specific legal rights, and you may also have other rights which vary from state to state or province to province.

Limitations: Implied warranties, including those of fitness for a particular purpose and merchantability (an unwritten warranty that the PRODUCT is fit for ordinary use) are limited to two years from date of purchase. Some states/provinces do not allow limitations on how long an implied warranty lasts, so the above limitation may not apply to you. In no event shall VTech be liable for any indirect, special, incidental, consequential, or similar damages (including, but not limited to lost profits or revenue, inability to use the PRODUCT or other associated equipment, the cost of substitute equipment, and claims by third parties) resulting from the use of this PRODUCT. Some states/provinces do not allow the exclusion or limitation of incidental or consequential damages, so the above limitation or exclusion may not apply to you.

Please retain your original sales receipt as proof of purchase.

Disclaimer and Limitation of Liability

VTech Communications, Inc. and its suppliers assume no responsibility for any damage or loss resulting from the use of this user's manual. VTech Communications, Inc. and its suppliers assume no responsibility for any

loss or claims by third parties that may arise through the use of this product.

VTech Communications, Inc. and its suppliers assume no responsibility for any damage or loss caused by deletion of data as a result of malfunction, dead battery, or repairs. Be sure to make backup copies of important data on other media to protect against data loss.

Company: VTech Communications, Inc.

Address: 9020 SW Washington Square Road - Ste 555 Tigard, OR 97223, United States

Phone: 1 (800) 595-9511 in the U.S.

Appendix

Troubleshooting

If you have difficulty with your product please try the suggestions below.

For customer service, visit our website at vtechphones.com, or call

1 (800) 595-9511.

My speakerphone does not work at all.

- Make sure the speakerphone charger power adapter is securely plugged into an electrical outlet (see “Connect power to the wireless speaker” on page 8). The POWER light should be on.
- Make sure the speakerphone is registered to the dongle (see “Registering the dongle” on page 10).
- Other electronic products such as HAM radios and other DECT phones can cause interference with your wireless speakerphone. Try installing your speakerphone as far away as possible from these types of electronic devices.
- If the speakerphone battery is completely depleted, it may take up to 15 minutes to charge the speakerphone before the speakerphone has enough charge to use for a short time.

The other party cannot hear my voice during a call.

- Make sure the mute feature is not turned on during a call.

I cannot hear any audio from the wireless speakerphone.

- Make sure the wireless speakerphone is enabled (see “Connecting the wireless speaker to a computer” on page 10) and the speaker volume is not set to the lowest level.
- On your computer, click the speaker icon (located at the bottom right hand corner in Microsoft Windows). Make sure “VTech Headset” is selected as current audio device.
- The speakerphone may be too far from the dongle. Move it closer to the dongle.

Appendix

Troubleshooting

My computer does not connect to the wireless speakerphone.

- Your DECT dongle is preregistered to the wireless speaker. If the dongle does not connect to the speaker, follow the deregistration and registration instructions. See “Deregistering the dongle” and “Registering the dongle” on page 10.
- Follow the steps below for the common cure for electronic equipment, then try again to register a speakerphone.

Common cure for electronic equipment.

- If the unit is not responding normally, try the following :
 - Unplug and then plug the dongle to the computer.
 - Wait for the wireless speakerphone to synchronize with the DECT dongle. Allow up to one minute for this to take place.

VTECH COMMUNICATIONS LTD.

A member of THE VTECH GROUP OF COMPANIES.

Distributed in the U.S.A. by VTech Communications Inc., Tigard, Oregon 97223, USA.

VTech is a registered trademark of VTech Holdings Limited.

ErisTerminal® is a registered trademark of VTech Communications Inc.

Copyright © 2020 for VTECH COMMUNICATIONS LTD. All rights reserved.

Printed in China. Version 1, 07/20