

Go to **www.vtechphones.com (US)**
to register your product for enhanced warranty
support and latest VTech product news.
Go to **phones.vtechcanada.com (Canada)** for
latest VTech product news.

SN1117

Amplified Coded with
Photo Speed Dial and Big Buttons

Scan the QR code for
support information



US



CAN

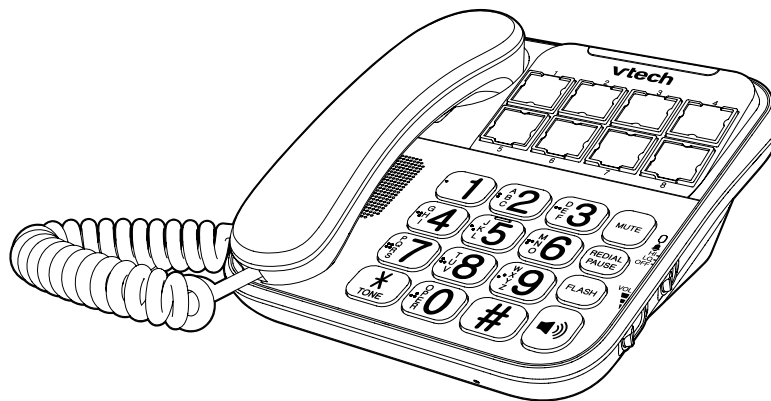

vtech[®]
User's manual

Congratulations

on purchasing your new VTech product. Before using this telephone, please read **Important safety instructions**.

This manual has all the feature operations necessary to install and operate your new VTech telephone. Please review this manual thoroughly to ensure proper installation and operation of this innovative and feature rich VTech product.

For support, shopping, and everything new at VTech, visit our website at **www.vtechphones.com**. In Canada, visit **phones.vtechcanada.com**.

Compatible with
Hearing Aid T-Coil



Telephones identified with this logo have reduced noise and interference when used with most T-coil equipped hearing aids and cochlear implants. The TIA-1083 Compliant Logo is a trademark of the Telecommunications Industry Association. Used under license.

Important safety instructions

When using your telephone equipment, basic safety precautions should always be followed to reduce the risk of fire, electric shock and injury, including the following:

1. Read and understand all instructions.
2. Follow all warnings and instructions marked on the product.
3. Do not use liquid or aerosol cleaners. Use a damp cloth for cleaning.
4. **CAUTION:** Do not install the telephone base at a height above 2 meters.
5. Do not use this product near water such as near a bath tub, wash bowl, kitchen sink, laundry tub or a swimming pool, or in a wet basement or shower.
6. Do not place this product on an unstable table, shelf, stand or other unstable surfaces.
7. Avoid placing the telephone system in places with extreme temperature, direct sunlight, or other electrical devices. Protect your phone from moisture, dust, corrosive liquids and fumes.
8. Slots and openings in the back or bottom of the telephone base and handset are provided for ventilation. To protect them from overheating, these openings must not be blocked by placing the product on a soft surface such as a bed, sofa or rug. This product should never be placed near or over a radiator or heat register. This product should not be placed in any area where proper ventilation is not provided.
9. This product should be operated only from the type of power source indicated on the marking label. If you are not sure of the type of power supply in your home or office, consult your dealer or local power company.
10. Never push objects of any kind into this product through the slots in the telephone base or handset because they may touch dangerous voltage points or create a short circuit. Never spill liquid of any kind on the product.
11. To reduce the risk of electric shock, do not disassemble this product, but take it to an authorized service facility. Opening or removing parts of the telephone base or

- handset other than specified access doors may expose you to dangerous voltages or other risks. Incorrect reassembling can cause electric shock when the product is subsequently used.
12. Refer servicing to an authorized service facility under the following conditions:
 - If liquid has been spilled onto the product.
 - If the product has been exposed to rain or water.
 - If the product does not operate normally by following the operating instructions. Adjust only those controls that are covered by the operation instructions. Improper adjustment of other controls may result in damage and often requires extensive work by an authorized technician to restore the product to normal operation.
 - If the product has been dropped and the telephone base and/or handset has been damaged.
 - If the product exhibits a distinct change in performance.
 13. Avoid using a telephone (other than cordless) during an electrical storm. There is a remote risk of electric shock from lightning.

14. Do not use the telephone to report a gas leak in the vicinity of the leak.
15. Only put the handset of your telephone next to your ear when it is in normal talk mode.
16. The applied nameplate is located at the bottom or near of the product.

SAVE THESE INSTRUCTIONS

For C-UL Compliance only

Mesures de sécurité importantes

Afin de réduire les risques d'incendie, de blessures corporelles ou d'électrocution, suivez toujours ces mesures préventives de base lorsque vous utilisez votre téléphone :

1. Lisez et comprenez bien toutes les instructions.
2. Observez toutes les instructions et mises en garde inscrites sur l'appareil.
3. N'utilisez pas de nettoyeurs liquides ni en aérosol. N'utilisez qu'un chiffon doux et légèrement humecté.
4. **ATTENTION:** Ne pas installer le socle téléphonique à une hauteur supérieure à 2 mètres.
5. N'utilisez pas ce produit près de l'eau, tel que

- près d'un bain, d'un lavabo, d'un évier de cuisine, d'un bac de lavage ou d'une piscine, ou dans un sous-sol humide ou sous la douche.
6. Ne déposez pas ce téléphone sur un chariot, support ou table chancelants. L'appareil pourrait tomber et être sérieusement endommagé.
 7. Évitez d'installer le système téléphonique dans les endroits soumis à une température extrême, à la lumière directe du soleil ou à proximité immédiate d'autres appareils électriques ou électroniques. Protégez votre téléphone contre les sources d'humidité, la poussière, les vapeurs et les liquides corrosifs.
 8. Le boîtier de l'appareil est doté de fentes et d'ouvertures d'aération situées à l'arrière ou en dessous. Afin d'empêcher la surchauffe, ces ouvertures ne doivent pas être obstruées en plaçant l'appareil sur un lit, divan, tapis ou autre surface similaires. Ne placez pas cet appareil à proximité d'un élément de chauffage ni d'une plinthe électrique. De plus, ne l'installez pas dans une unité murale ou un cabinet fermé qui ne possède pas d'aération adéquate.
 9. Ne faites fonctionner cet appareil qu'avec le type d'alimentation indiqué sur les étiquettes de l'appareil. Si vous ne connaissez pas le voltage de votre maison, consultez votre marchand ou votre fournisseur d'électricité.
 10. N'insérez jamais d'objets à travers les fentes et ouvertures de cet appareil, car ils pourraient toucher à des points de tension dangereux ou court-circuiter des pièces, ce qui constituerait un risque d'incendie ou d'électrocution. N'échappez pas de liquides dans l'appareil.
 11. Afin de réduire les risques d'électrocution, ne démontez pas l'appareil, mais apportez-le plutôt à un centre de service qualifié s'il doit être réparé. En enlevant le couvercle, vous vous exposez à des tensions dangereuses ou autres dangers similaires. Un remontage inadéquat peut être à l'origine d'une électrocution lors d'une utilisation ultérieure de l'appareil. Débranchez l'appareil avant de procéder au nettoyage. Utilisez un chiffon humide et doux.
 12. Communiquez avec le département de service à la clientèle de VTech dans les cas suivants :
 - Si du liquide a été échappé dans l'appareil.
 - Si l'appareil a été exposé à une source d'humidité telle que la pluie ou l'eau.

- Si le produit ne fonctionne pas normalement en respectant les instructions de fonctionnement. Réglez uniquement les commandes indiquées dans le les instructions de fonctionnement. Les réglages incorrects des autres commandes pourraient provoquer un dommage qui pourrait exiger un travail exhaustif de la part d'un technicien autorisé afin de rétablir le fonctionnement normal de l'appareil.
 - Si le produit a été échappé et que le socle et/ou le combiné a été endommagé.
 - Si le produit affiche une nette diminution de sa performance.
13. Évitez d'utiliser un téléphone (autre qu'un sans fil) pendant un orage. Les éclairs peuvent être à l'origine d'une électrocution.
 14. N'utilisez pas le téléphone pour rapporter une fuite de gaz à proximité de la fuite.
 15. Ne placez que le combiné de votre téléphone près de votre oreille lorsqu'en mode de conversation.
 16. La plaque signalétique appliquée est située au bas ou à proximité du produit.

CONSERVEZ CES INSTRUCTIONS

FCC, ACTA and IC Regulations

FCC Part 15

NOTE: This equipment has been tested and found to comply with the requirements for a Class B digital device under Part 15 of the Federal Communications Commission (FCC) rules. These requirements are intended to provide reasonable protection against harmful interference in a residential installation.

This equipment generates, uses and can radiate radio frequency energy and, if not installed and used in accordance with the instructions, may cause harmful interference to radio communications. However, there is no guarantee that interference will not occur in a particular installation. If this equipment does cause harmful interference to radio or television reception, which can be determined by turning the equipment off and on, the user is encouraged to try to correct the interference by one or more of the following measures:

- Reorient or relocate the receiving antenna.
- Increase the separation between the equipment and receiver.

- Connect the equipment into an outlet on a circuit different from that to which the receiver is connected.
- Consult the dealer or an experienced radio/TV technician for help.

WARNING: Changes or modifications to this equipment not expressly approved by the party responsible for compliance could void the user's authority to operate the equipment.

This device complies with Part 15 of the FCC rules. Operation is subject to the following two conditions: (1) this device may not cause harmful interference, and (2) this device must accept any interference received, including interference that may cause undesired operation. Privacy of communications may not be ensured when using this telephone.

This Class B digital apparatus complies with Canadian requirement:
CAN ICES-3 (B)/NMB-3(B).

FCC Part 68 and ACTA

This equipment complies with Part 68 of the FCC rules and with technical requirements adopted by the Administrative Council for Terminal Attachments (ACTA). The label on the back or bottom of this equipment contains, among other things, a product identifier in the format US:AAAEQ##TXXXX. This identifier must be provided to your telephone service provider upon request.

The plug and jack used to connect this equipment to premises wiring and the telephone network must comply with applicable Part 68 rules and technical requirements adopted by ACTA.

A compliant telephone cord and modular plug is provided with this product. It is designed to be connected to a compatible modular jack that is also compliant. An RJ11 jack should normally be used for connecting to a single line. See the installation instructions in the user's manual.

The Ringer Equivalence Number (REN) is used to determine how many devices you may connect to your telephone line and still have them ring when you are called. The REN for this product is encoded as the 6th and 7th characters following the US: in the

product identifier (e.g., if ## is 03, the REN is 0.3). In most, but not all areas, the sum of all RENs should be five (5.0) or less. For more information, please contact your telephone service provider.

This equipment must not be used with Party Lines. If you have specially wired alarm dialing equipment connected to your telephone line, ensure the connection of this equipment does not disable your alarm equipment. If you have questions about what will disable alarm equipment, consult your telephone service provider or a qualified installer.

If this equipment is malfunctioning, it must be unplugged from the modular jack until the problem has been corrected. Replacement to this telephone equipment can only be made by the manufacturer or its authorized agents. For replacement procedures, follow the instructions outlined under the Limited warranty.

If this equipment is causing harm to the telephone network, the telephone service provider may temporarily discontinue your telephone service. The telephone service provider is required to notify you before interrupting service. If advance notice is not practical, you will be notified as soon as possible. You

will be given the opportunity to correct the problem and the telephone service provider is required to inform you of your right to file a complaint with the FCC. Your telephone service provider may make changes in its facilities, equipment, operation, or procedures that could affect the proper functioning of this product. The telephone service provider is required to notify you if such changes are planned.

This product is equipped with a corded handset, it is hearing aid compatible.

If this product has memory dialing locations, you may choose to store emergency telephone numbers (e.g., police, fire, medical) in these locations. If you do store or test emergency numbers, please:

Remain on the line and briefly explain the reason for the call before hanging up.

Perform such activities in off-peak hours, such as early morning or late evening.

Industry Canada

This device contains licence-exempt transmitter(s)/ receiver(s) that comply with Innovation, Science and Economic Development Canada's licence-exempt RSS(s). Operation is subject to the following two

conditions:

- (1) This device may not cause interference.
- (2) This device must accept any interference, including interference that may cause undesired operation of the device.

Privacy of communications may not be ensured when using this telephone.

The term "IC:" before the certification/registration number only signifies that the Industry Canada technical specifications were met.

The Ringer Equivalence Number (REN) for this terminal equipment is 0.6. The REN indicates the maximum number of devices allowed to be connected to a telephone interface. The termination of an interface may consist of any combination of devices subject only to the requirement that the sum of the RENs of all the devices not exceed five.

This product meets the applicable Innovation, Science and Economic Development Canada technical specifications.

Disclaimer and Limitation of Liability

VTech Communications, Inc. and its suppliers assume no responsibility for any damage or loss resulting from the use of this user's manual. VTech Communications, Inc. and its suppliers assume no responsibility for any loss or claims by third parties that may arise through the use of this product.

Company: VTech Communications, Inc.

Address: 9020 SW Washington Square Road - Ste 555 Tigard, OR 97223, United States

Phone: 1 (800) 595-9511 in the U.S. or
1 (800) 267-7377 in Canada

What's in the box	1	Call waiting	18
		Redial	19
Connect and install	2	Photo/memory speed dial	19
Connect the telephone base	2	Product care Need	
Mount the telephone base (optional)	3	help?	20
Overview	7	Limited warranty	22
Setup	11		
Photo speed dial	11		
Talking digits	14		
Dial mode	15		
Operate	16		
Make a call	16		
Answer a call / End a call	16		
Speakerphone	16		
Volume - Speaker / Ringer	17		
Temporary ringer silencing	18		

What's in the box

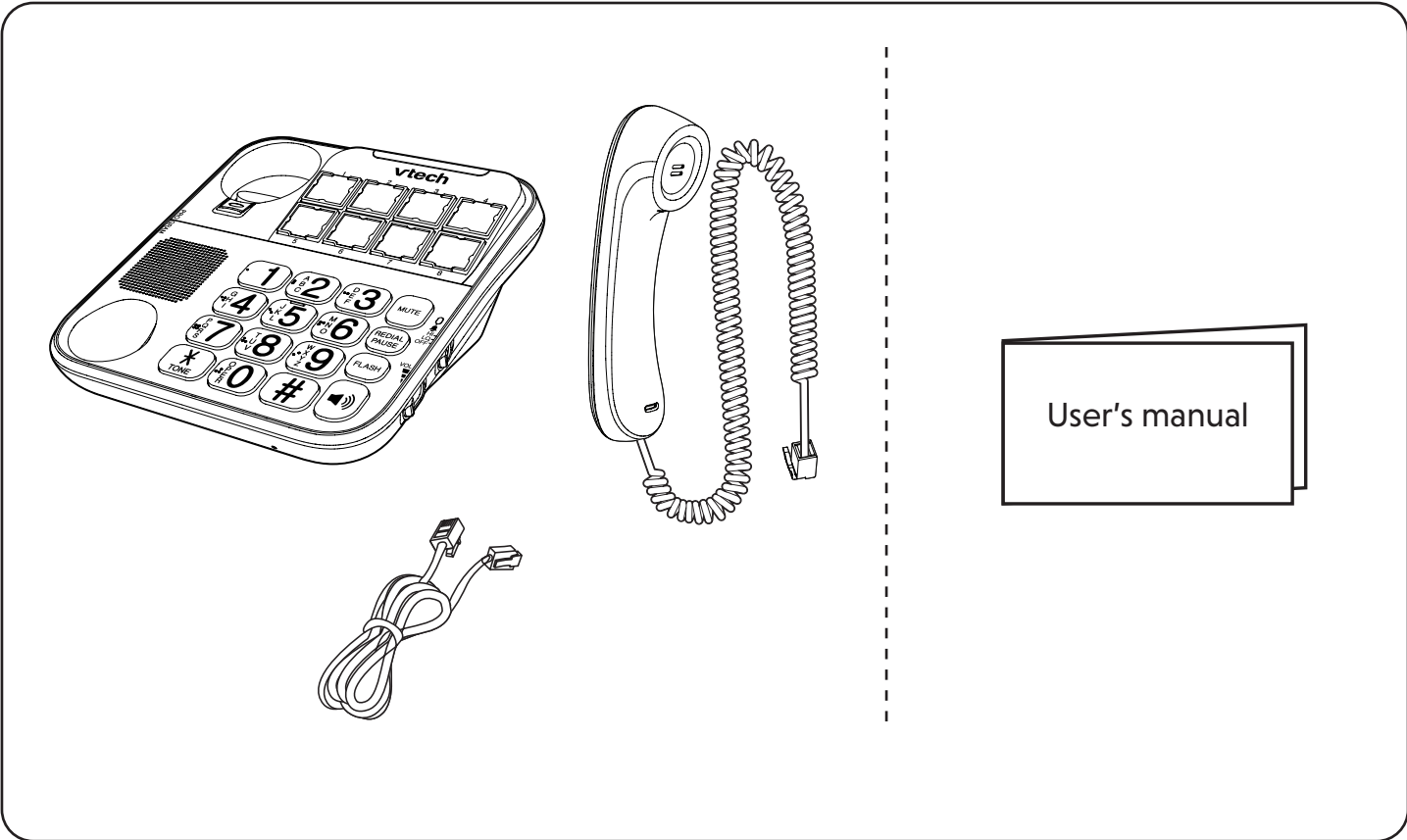

User's manual

Connect and install

Connect the telephone base

If you subscribe to digital subscriber line (DSL) high-speed Internet service through your telephone line, make sure you connect a DSL filter (not included) to the telephone wall jack.

The base is line-powered. There is no external power source nor any battery backup.

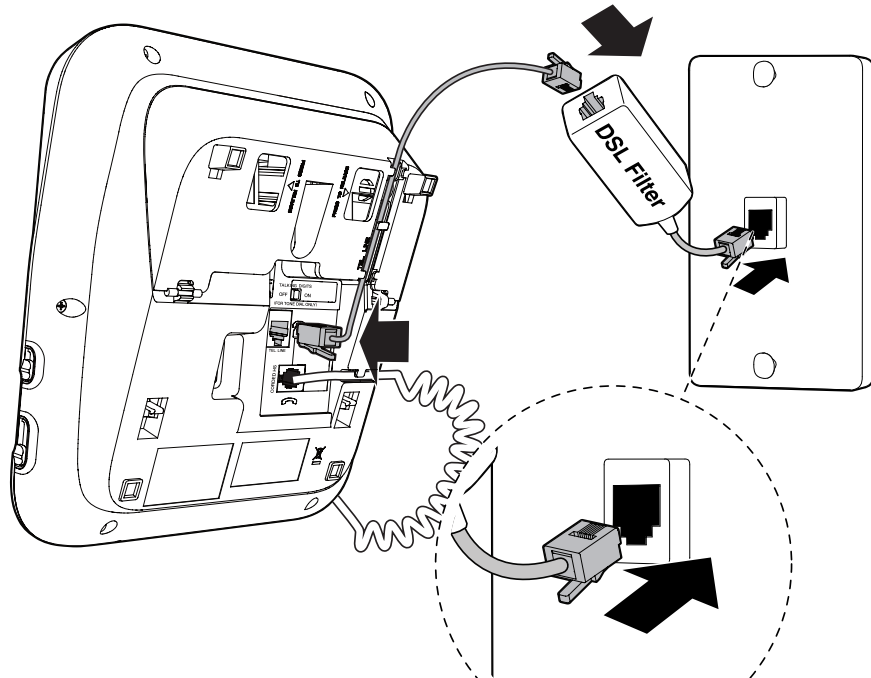

Connect and install

Mount the telephone base (optional)

- 1 On the **rear side of the telephone base**, press the tabs of the wall-mount bracket to release it from the tabletop orientation.

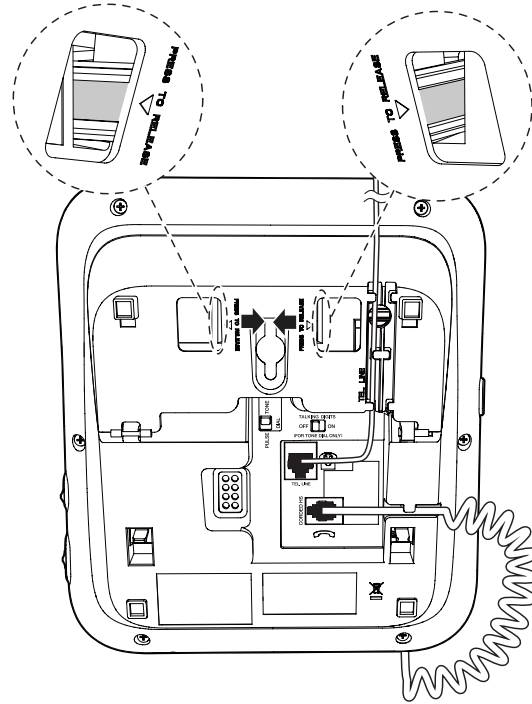

Connect and install

2

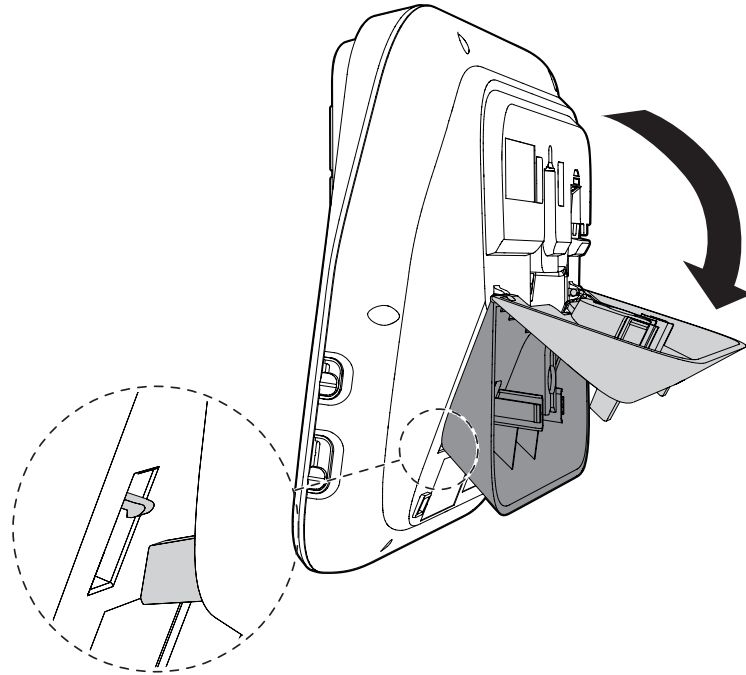

Flip the wall-mount bracket down and push it into the telephone base until it clicks into place.

Connect and install

3

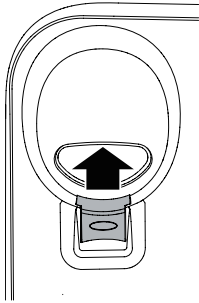

Slide the handset
tab upward.

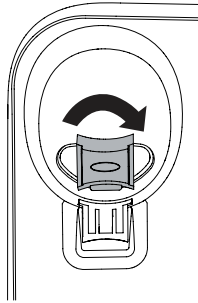

Rotate it upside
down.

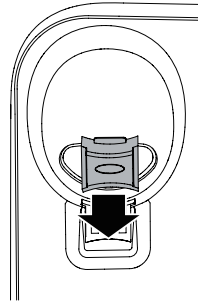

Slide the handset
tab back into the
slot.

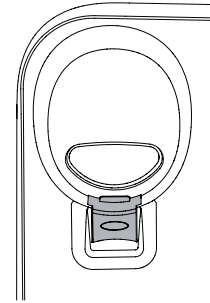

The protruding edge of the handset tab holds the corded handset in place when the telephone is mounted on the wall.

Connect and install

4

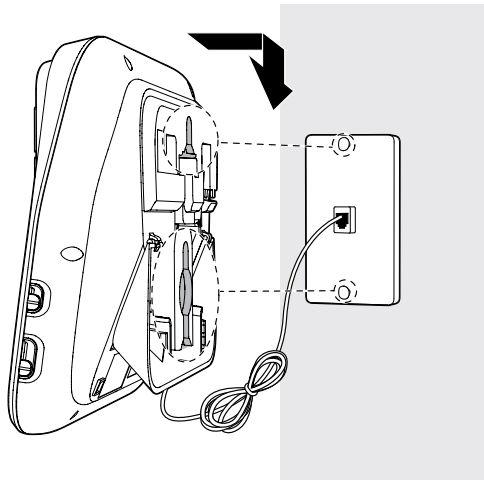

Align and mount the bracket to the telephone wall mount plate.

5



Overview

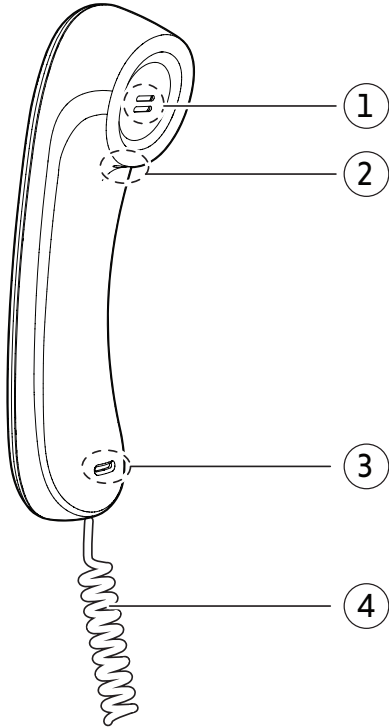

1 **Handset earpiece**

2 **Slot for handset tab**
• For optional wall mounting.



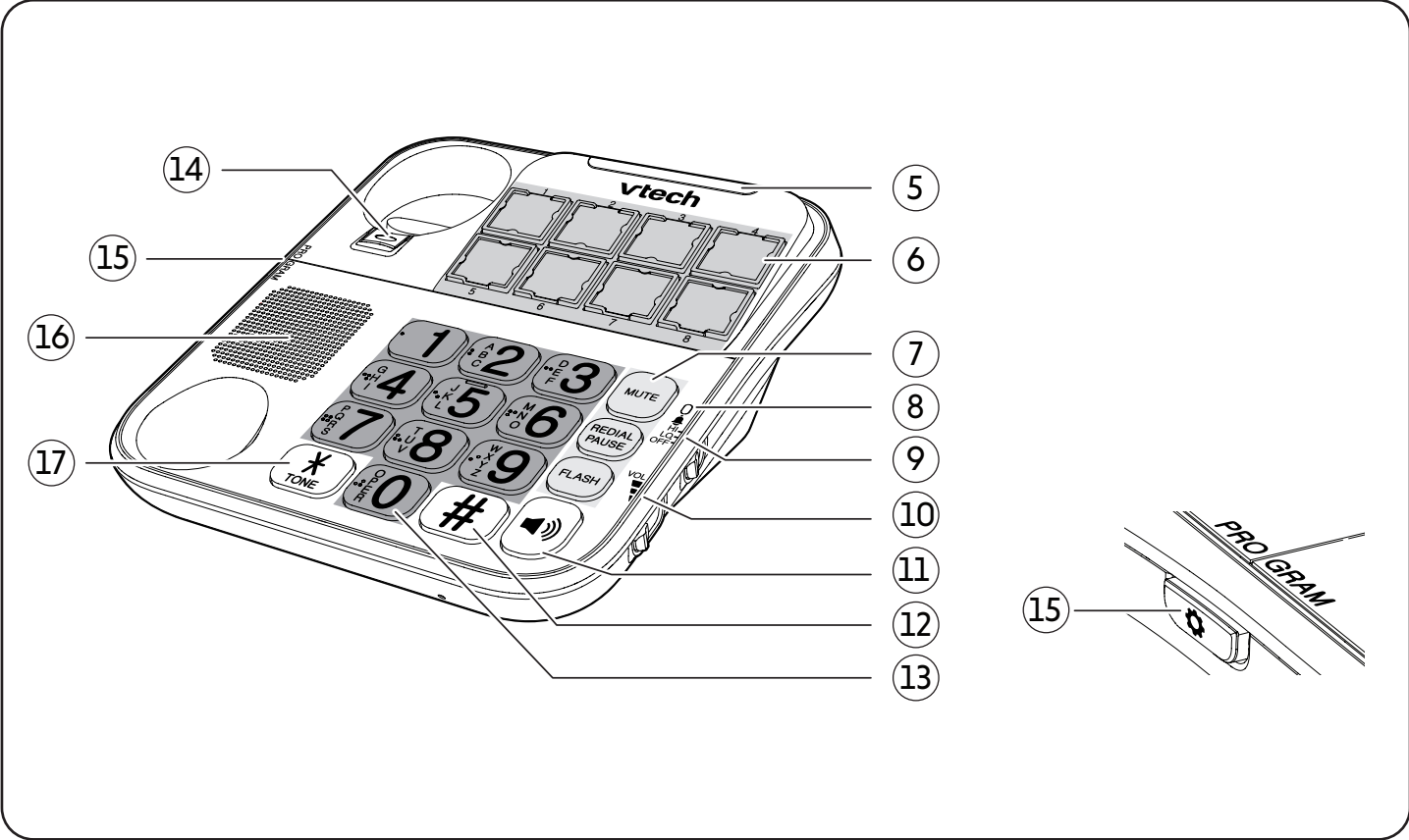

3 **Handset microphone**

4 **Coiled handset cord**





Overview



Overview

5	Visual ringer indicator / Line in use LED	<ul style="list-style-type: none">• On when the telephone is in use.• Flashes to indicate an incoming call.
6	8 photo speed dial keys	<ul style="list-style-type: none">• Press to dial the preset numbers.
		<ul style="list-style-type: none">• Mute the microphone during a call.
7		<ul style="list-style-type: none">• Press to redial the last number.• Press to add pause if it is required for dialing.
		<ul style="list-style-type: none">• During a call, press to answer an incoming call when you receive a call waiting alert.
8	MUTE LED	
9		<ul style="list-style-type: none">• Adjust the base ringer volume while in idle.

Overview

10		<ul style="list-style-type: none">• Adjust the listening volume during a call.
11		<ul style="list-style-type: none">• Press to make or answer a call using the speakerphone.
12		<ul style="list-style-type: none">• Pound key.
13	Dialing keys (0-9)	
14	Handset tab	<ul style="list-style-type: none">• For optional wall mounting.
15	 / Program	<ul style="list-style-type: none">• Store the number to the selected memory key location.
16	Speaker	
17		<ul style="list-style-type: none">• Switch to tone dialing temporarily during a call.

Setup



Photo speed dial

There are eight photo speed dial memory keys numbered **1** to **8** on the telephone base. You can store the telephone numbers you wish to quick dial to the photo speed dial keys.

☀ TIPS



- All eight photo speed dial memory keys are empty and you will need to store numbers to these keys.
- We recommend you store at least two contacts that you may need to call more often or immediately to photo speed dial keys **1** and **2**.

Add / Change / Remove a photo speed dial number

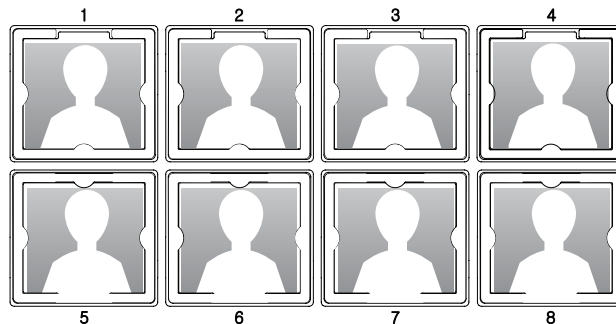
1. Press  when the telephone is not in use.
 - The **Line in use LED** turns on.
2. Press  on the side of the telephone base.
3. Press to select one of the photo speed dial memory keys **1** to **8**.
 - The telephone then enters programming mode while emitting 3 beeps. The **MUTE LED** turns on.



Setup

4. Press the dialing keys to input the telephone number.
5. Press  to store the number to the selected photo speed dial memory key location.
 - You will hear a confirmation tone when the number is saved. The **Line in use LED** and **MUTE LED** turn off.
 - The newly input number will replace the previous one if the memory key had a phone number assigned before.
 - If no number is entered before the  key is pressed again, then the memory location is empty. This will remove a speed dial number if you have assigned one previously.

Dial a speed dial number while offhook

1. Lift the corded handset or press  to use the speakerphone.
2. Press the photo speed dial memory key (**1 - 8**) you want to dial.
 - The stored number will dial out automatically.
 - If there is no number stored in that memory location, an error tone will be emitted.

Setup

Insert photos for speed dial keys

You can insert photos into the photo speed dial compartments, or write the contact names on cards and insert them into the compartments.

NOTE

- The telephone base is shipped with protective stickers covering the photo speed dial compartments. Remove the protective sticker before use.

1. Remove the photo speed dial compartment cover.
2. Crop your desired photo into the size specified on the right, and then insert it into the photo speed dial compartment.
3. Insert the photo speed dial compartment cover back to the compartment.

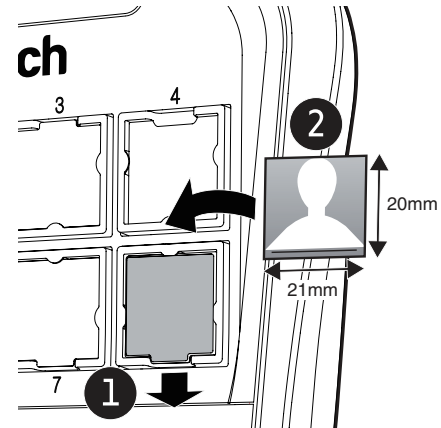

Setup



Talking digits

At the base bottom, you can turn on or off the Talking digits feature. It announces the number while pressing each digit in offhook mode or during speed dial number storing.

NOTE

- The Talking digits feature is available in Touch tone [**TONE DIAL**] mode only.

Language setting for Talking digits (Canadian version only)

1. Press , and the **Line in use LED** is on.
2. Press , and then press  within 3 seconds.
 - You will hear an administrative tone for entering the programming mode. The **MUTE LED** turns on.
3. Press **364#** to select **English**, or press **373#** to select **French**.
 - You will hear a confirmation tone when it is set.

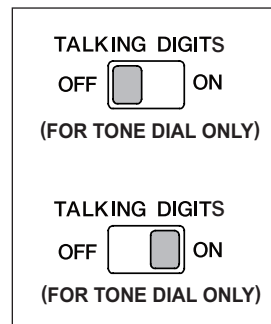

Setup

Dial mode

At the base bottom, you can select the dial mode by sliding the switch - Pulse dialing [**PULSE**] or Touch tone [**TONE**].

- If you need to temporarily switch to Touch tone mode, you can press  while offhook.

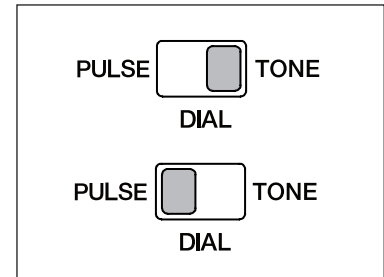

Operate

Make a call



Press  or lift the corded handset.

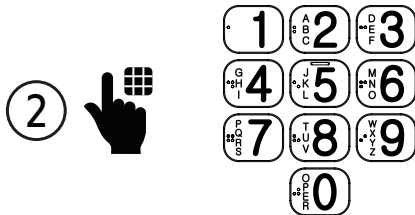

Dial the telephone number.

Answer a call / End a call

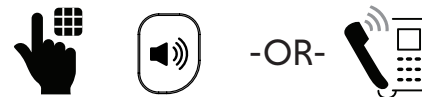

To answer a call, press  or lift the corded handset.

To end a call, press  again or hang up the corded handset.

Speakerphone



While using the corded handset, press  on the telephone base to switch to speakerphone.

Operate

Volume - Speaker / Ringer

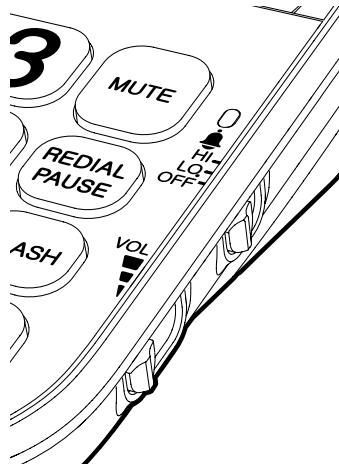

Slide the **VOL** control to adjust the corded handset or the speaker volume level when idle or on a call.



Slide the **Ringer** control to adjust the ringer volume level.

- You cannot change the ringer tone.

⚠ CAUTION

- For hearing protection, loud ringer and sound may damage your hearing. Adjust the volume to lower the ringer and sound if you find it too loud.



Operate

Temporary ringer silencing



When the telephone is ringing, you can press **MUTE** to temporarily silence the ringer without disconnecting the call. The next call rings normally at the preset volume.

Call waiting

When you subscribe to call waiting service from your telephone service provider, you hear an alert tone if there is an incoming call while you are already on a call.



1. Press **FLASH** on the telephone base to put the current call on hold and take the new call.
2. Press **FLASH** at any time to switch back and forth between calls.

Operate

Redial

The last dialed telephone number is stored in the telephone base.



To redial the last number, press the speakerphone or lift the corded handset.



Then, press **REDIAL**.

Photo/memory speed dial

If you have set any speed dial numbers, you can press a photo speed dial key to quickly dial the preset number.

For details on setting photo/memory speed dial, see page 11.

Speakerphone mode

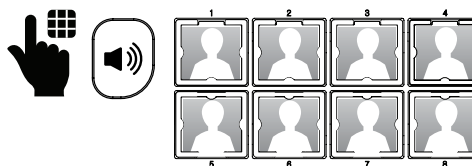

Press  and then press a photo speed dial key to call.

Handset mode

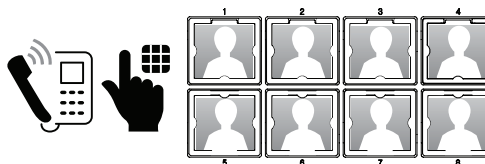

Lift the handset, and then press a photo speed dial key to call.

Product care | Need help?

Taking care of your telephone

Your telephone contains sophisticated electronic parts, so it must be treated with care.

Avoid rough treatment

Place the handset down gently. Save the original packing materials to protect your telephone if you ever need to ship it.

Avoid water

Your telephone can be damaged if it gets wet. Do not use the handset outdoors in the rain, or handle it with wet hands. Do not install the telephone base near a sink, bathtub or shower.

Electrical storms

Electrical storms can sometimes cause power surges harmful to electronic equipment. For your own safety, take caution when using electrical appliances during storms.

Cleaning your telephone

Your telephone has a durable plastic casing that should retain its luster for many years. Clean it only with a dry non-abrasive cloth. Do not use dampened cloth or cleaning solvents of any kind.

Product care | Need help?

For operations and guides to help you using your telephone, and for the latest information and supports, go and check the online help topics and online FAQs.

Use your smartphone or mobile device to access our online help.

- Go to <https://help.vtechphones.com/sn1117> (US); OR <https://phones.vtechcanada.com/en/support/general/manuals?model=sn1117> (Canada)
- Scan the QR code on the right. Launch the camera app or QR code scanner app on your smartphone or tablet. Hold the device's camera up to the QR code and frame it. Tap the notification to trigger the redirection of the online help.
- If the QR code is not clearly displayed, adjust your camera's focus by moving your device closer or further away until it is clear.



US



CAN

You can also call our Customer Support at 1 (800) 595-9511 [in US] or 1 (800) 267-7377 [in Canada] for help.

Limited warranty

What does this limited warranty cover?

The manufacturer of this VTech Product warrants to the holder of a valid proof of purchase ("Consumer" or "you") that the Product and all accessories provided in the sales package ("Product") are free from defects in material and workmanship, pursuant to the following terms and conditions, when installed and used normally and in accordance with the Product operating instructions. This limited warranty extends only to the Consumer for Products purchased and used in the United States of America and Canada.

What will VTech do if the Product is not free from defects in materials and workmanship during the limited warranty period ("Materially Defective Product")?

During the limited warranty period, VTech's authorized service representative will replace at VTech's option, without charge, a Materially Defective Product. If we choose to replace the Product, we may replace it with a new or refurbished Product of the same or similar design. We will retain defective parts, modules, or equipment. Replacement of the Product, at VTech's option, is your exclusive remedy. VTech will return the replacement Products to you in working condition. You should expect the replacement to take approximately 30 days.

How long is the limited warranty period?

The limited warranty period for the Product extends for ONE (1) YEAR from the date of purchase. If VTech replaces a Materially Defective Product under the terms of this limited warranty, this

limited warranty also applies to the replacement Product for a period of either (a) 90 days from the date the replacement Product is shipped to you or (b) the time remaining on the original one-year warranty; whichever is longer.

What is not covered by this limited warranty?

This limited warranty does not cover:

1. Product that has been subjected to misuse, accident, shipping or other physical damage, improper installation, abnormal operation or handling, neglect, inundation, fire, water or other liquid intrusion;
2. Product that has been damaged due to repair, alteration or modification by anyone other than an authorized service representative of VTech;
3. Product to the extent that the problem experienced is caused by signal conditions, network reliability, or cable or antenna systems;
4. Product to the extent that the problem is caused by use with non-VTech accessories;
5. Product whose warranty/quality stickers, product serial number plates or electronic serial numbers have been removed, altered or rendered illegible;
6. Product purchased, used, serviced, or shipped for repair from outside the United States of America or Canada, or used for commercial or institutional purposes (including but not limited to Products used for rental purposes);
7. Product returned without a valid proof of purchase (see item 2 below); or

Limited warranty

- Charges for installation or set up, adjustment of customer controls, and installation or repair of systems outside the unit.

How do you get warranty service?

To obtain warranty service in the USA, please visit our website at www.vtechphones.com or call 1 (800) 595-9511. In Canada, go to phones.vtechcanada.com or call 1 (800) 267-7377.

NOTE: Before calling for service, please review the user's manual - a check of the Product's controls and features may save you a service call.

Except as provided by applicable law, you assume the risk of loss or damage during transit and transportation and are responsible for delivery or handling charges incurred in the transport of the Product(s) to the service location. VTech will return replaced Product under this limited warranty. Transportation, delivery or handling charges are prepaid. VTech assumes no risk for damage or loss of the Product in transit. If the Product failure is not covered by this limited warranty, or proof of purchase does not meet the terms of this limited warranty, VTech will notify you and will request that you authorize the cost of replacement prior to any further replacement activity. You must pay for the cost of replacement and return shipping costs for the replacement of Products that are not covered by this limited warranty.

What must you return with the Product to get warranty service?

- Return the entire original package and contents including the Product to the VTech service location along with a description of the malfunction or difficulty; and
- Include a "valid proof of purchase" (sales receipt) identifying the Product purchased (Product model) and the date of purchase or receipt; and
- Provide your name, complete and correct mailing address, and telephone number.

Other limitations

This warranty is the complete and exclusive agreement between you and VTech. It supersedes all other written or oral communications related to this Product. VTech provides no other warranties for this Product. The warranty exclusively describes all of VTech's responsibilities regarding the Product. There are no other express warranties. No one is authorized to make modifications to this limited warranty and you should not rely on any such modification.

State/Provincial Law Rights: This warranty gives you specific legal rights, and you may also have other rights, which vary from state to state or province to province.

Limitations: Implied warranties, including those of fitness for a particular purpose and merchantability (an unwritten warranty that the Product is fit for ordinary use) are limited to one year from the date of purchase. Some states/provinces do not allow limitations on how long an implied warranty lasts, so the

Limited warranty

above limitation may not apply to you. In no event shall VTech be liable for any indirect, special, incidental, consequential, or similar damages (including, but not limited to lost profits or revenue, inability to use the Product or other associated equipment, the cost of substitute equipment, and claims by third parties) resulting from the use of this Product. Some states/provinces do not allow the exclusion or limitation of incidental or consequential damages, so the above limitation or exclusion may not apply to you.

Please retain your original sales receipt as proof of purchase



Recycle this product when you are done with it

Scan the QR code on the right or visit www.vtechphones.com/recycle.



(For the US only)



Specifications are subject to change without notice.
© 2025 VTech Communications, Inc. |
© 2025 VTech Technologies Canada Ltd.
All rights reserved. 01/25. SN1117_UM_V1

