

Go to www.vtechphones.com (US)
to register your product for
enhanced warranty support and
the latest VTech product news.

Go to phones.vtechcanada.com
(Canada) for the latest VTech
product news.

LS6425 LS6426-3
LS6425-2 LS6426-4
LS6425-3 LS642V-1E
LS6425-4 LS642V-1F
LS642V-1G

DECT 6.0 cordless telephone



Scan the QR code for
support information



(US)



(CA)

vtech[®]
User's manual

Congratulations

on purchasing your new VTech product. Before using this telephone, please read **Important safety instructions**.

This manual has all the feature operations and troubleshooting necessary to install and operate your new VTech telephone. Please review this manual thoroughly to ensure proper installation and operation of this innovative and feature rich VTech product.

For support, shopping, and everything new at VTech, visit our website at www.vtechphones.com.



In Canada, please visit phones.vtechcanada.com.



Telephones identified with this logo have reduced noise and interference when used with most T-coil equipped hearing aids and cochlear implants. The TIA-1083 Compliant Logo is a trademark of the Telecommunications Industry Association. Used under license.

Important safety instructions

When using your telephone equipment, basic safety precautions should always be followed to reduce the risk of fire, electric shock and injury, including the following:

1. Read and understand all instructions.
2. Follow all warnings and instructions marked on the product.
3. Unplug this product from the wall outlet before cleaning. Do not use liquid or aerosol cleaners. Use a damp cloth for cleaning.
4. **CAUTION:** Do not install the telephone base at a height above 2 meters.
5. Do not use this product near water such as near a bath tub, wash bowl, kitchen sink, laundry tub or swimming pool, or in a wet basement or shower.
6. Do not place this product on an unstable table, shelf, stand or other unstable surfaces.
7. Avoid placing the telephone system in places with extreme temperature, direct sunlight, or other electrical devices. Protect your phone from moisture, dust, corrosive liquids and fumes.
8. Slots and openings in the back or bottom of the telephone base and handset are provided for ventilation. To protect them from overheating, these openings must not be blocked by placing the product on a soft surface such as a bed, sofa or rug. This product should never be placed near or over a radiator or heat register. This product should not be placed in any area where proper ventilation is not provided.
9. This product should be operated only from the type of power source indicated on the marking label. If you are not sure of the type of power supply in your home or office, consult your dealer or local power company.
10. Do not allow anything to rest on the power cord. Do not install this product where the cord may be walked on.
11. Never push objects of any kind into this product through the slots in the telephone base or handset because they may touch dangerous voltage points or create a short circuit. Never spill liquid of any kind on the product.
12. To reduce the risk of electric shock, do not disassemble this product, but take it to an authorized service facility. Opening or removing parts of the telephone base or handset other than specified access doors may expose you to dangerous voltages or other risks. Incorrect reassembling can cause electric shock when the product is subsequently used.
13. Do not overload wall outlets and extension cords.
14. Unplug this product from the wall outlet and refer servicing to an authorized service facility under the following conditions:
 - When the power supply cord or plug is damaged or frayed.
 - If liquid has been spilled onto the product.
 - If the product has been exposed to rain or water.
 - If the product does not operate normally by following the operating instructions. Adjust only those controls that are covered by the operation instructions. Improper adjustment of other controls may result in damage and often requires extensive work by an authorized technician to restore the product to normal operation.
 - If the product has been dropped and the telephone base and/or handset has been damaged.
 - If the product exhibits a distinct change in performance.
15. Avoid using a telephone (other than cordless) during an electrical storm. There is a remote risk of electric shock from lightning.
16. Do not use the telephone to report a gas leak in the vicinity of the leak. Under certain circumstances, a spark may be created when the adapter is plugged into the power outlet, or when the handset is replaced in its cradle. This is a common event associated with the closing of any electrical circuit. The user should not plug the phone into a power outlet, and should not put a charged handset into the cradle, if the phone is located in an environment containing concentrations of flammable or flame-supporting gases, unless there is adequate ventilation. A spark in such an environment could create a fire or explosion. Such environments might include: medical use of oxygen without adequate ventilation; industrial gases (cleaning solvents; gasoline vapors; etc.); a leak of natural gas; etc.
17. Only put the handset of your telephone next to your ear when it is in normal talk mode.
18. The power adapters are intended to be correctly oriented in a vertical or floor mount position. The prongs are not designed to hold the plug in place if it is plugged into a ceiling, under-the-table or cabinet outlet.
19. For pluggable equipment, the socket outlet shall be installed near the equipment and shall be easily accessible.
20.   **CAUTION:** Use only the batteries indicated in this manual. There may be a risk of explosion if a wrong type of battery is used for the handset. Use only the supplied rechargeable batteries or replacement batteries for the handset. Do not dispose of batteries in a fire. They may explode. Dispose of used batteries according to the instruction.
 - Do not use the battery in following conditions:
 - High or low extreme temperature during use, storage or

transportation.

- Replacement of a battery with an incorrect type that can defeat a safeguard.
- Disposal of a battery into fire or a hot oven, or mechanically crushing or cutting of a battery, that can result in an explosion.
- Leaving a battery in an extremely high temperature surrounding environment that can result in an explosion or the leakage of flammable liquid or gas.
- A battery subjected to extremely low air pressure that can result in an explosion or the leakage of flammable liquid or gas.

21. Use only the adapter included with this product. Incorrect adapter polarity or voltage can seriously damage the product.
22. The applied nameplate is located at the bottom or near of the product.

SAVE THESE INSTRUCTIONS

Battery

- Use only the battery provided or equivalent. To order a replacement, visit our website at www.vtechphones.com or call 1 (800) 595-9511. In Canada, go to phones.vtechcanada.com or call 1 (800) 267-7377.
- Do not dispose of the battery in a fire. Check with local waste management codes for special disposal instructions.
- Do not open or mutilate the battery. Released electrolyte is corrosive and may cause burns or injury to the eyes or skin. The electrolyte may be toxic if swallowed.
- Exercise care in handling batteries in order not to create a short circuit with conductive materials.
- Charge the battery provided with this product only in accordance with the

instructions and limitations specified in this manual.

Precautions for users of implanted cardiac pacemakers

Cardiac pacemakers (applies only to digital cordless telephones):

Wireless Technology Research, LLC (WTR), an independent research entity, led a multidisciplinary evaluation of the interference between portable wireless telephones and implanted cardiac pacemakers. Supported by the U.S. Food and Drug Administration, WTR recommends to physicians that:

Pacemaker patients

- Should keep wireless telephones at least six inches from the pacemaker.
- Should NOT place wireless telephones directly over the pacemaker, such as in a breast pocket, when it is turned ON.
- Should use the wireless telephone at the ear opposite the pacemaker.

WTR's evaluation did not identify any risk to bystanders with pacemakers from other persons using wireless telephones.

About cordless telephones

- **Privacy:** The same features that make a cordless telephone convenient create some limitations. Telephone calls are transmitted between the telephone base and the cordless handset by radio waves, so there is a possibility that the cordless telephone conversations could be intercepted by radio receiving equipment within range of the cordless handset. For this reason, you should not think of cordless telephone conversations as being as private as those on corded telephones.
- **Electrical power:** The telephone base of this cordless telephone must be connected to a working electrical outlet. The electrical outlet should not be

controlled by a wall switch. Calls cannot be made from the cordless handset if the telephone base is unplugged, switched off or if the electrical power is interrupted.

- **Potential TV interference:** Some cordless telephones operate at frequencies that may cause interference to televisions and VCRs. To minimize or prevent such interference, do not place the telephone base of the cordless telephone near or on top of a TV or VCR. If interference is experienced, moving the cordless telephone farther away from the TV or VCR often reduces or eliminates the interference.
- **Rechargeable batteries:** Exercise care in handling batteries in order not to create a short circuit with conducting material such as rings, bracelets and keys. The battery or conductor may overheat and cause harm. Observe proper polarity between the battery and the battery charger.
- **Nickel-metal hydride rechargeable batteries:** Dispose of these batteries in a safe manner. Do not burn or puncture the battery. Like other batteries of this type, if burned or punctured, they could release caustic material which could cause injury.

Table of contents

What's in the box	1
Overview	2
Telephone base overview	2
Handset overview	2
Display icons overview	4
Telephone base lights overview	4
Handset lights overview	4
Connect	5
Connect the telephone base	5
Connect the charger	5
Mount the telephone base	5
Tabletop to wall mount installation	5
Wall mount to tabletop installation	6
Install the battery	7
Check the battery level	7
Charge the battery	7
Before use	8
Set date and time	8
Check for dial tone	8
Operating range	9
Configure your telephone	9
Use the handset menu	9
Set date and time	9
Set LCD language	10
Set voice language	10
Caller ID announce	10
CID time synchronization	11
Dial mode	11
Telephone operations	12
Make a call	12
Predial a call	12
Answer a call	12
End a call	12
Speakerphone	12
Listening volume	13
Mute	13
Temporary ringer silencing	13
Temporary tone dialing	13
Find handset	14
Call waiting	14
Equalizer	14
Chain dialing	15

Redial list	15
Review a redial list entry	15
Dial a redial list entry	15
Delete a redial list entry	15
Copy a number from the redial list to the directory	16
Multiple handset use	16
Join a call in progress (for multiple handset models only)	16
Intercom	17
Answer an incoming call during an intercom call	18
Transfer a call	18
Blind transfer	19
Push-to-talk (PTT)	19
Directory	23
Add a directory entry	23
Review a directory entry	24
Alphabetical search	24
Dial a directory entry	24
Edit a directory entry	24
Delete the directory entries	25
Speed dial	25
Assign a directory entry to a speed dial location	25
Dial a speed dial entry	25
Reassign a speed dial number	26
Delete a speed dial entry	26
Caller ID	26
Review a caller ID log entry	27
Memory match	27
Missed call indicator	27
View dialing options	27
Dial a caller ID log entry	27
Save a caller ID log entry to the directory	28
Delete the caller ID log entries	28
Caller ID log display screen messages	28
Sound settings	29
Key tone	29
Ringer tone	29
Ringer volume	29
Telephone base ringer volume	29

About the built-in answering system and voicemail service..... 30

Set your built-in answering system 30
 Turn the answering system on or off31
 Default announcement31
 Record your own announcement31
 Play your announcement32
 Delete your announcement32
 Set number of rings32
 Turn the call screening on or off.....32
 Turn the message alert tone on or off.....33
 Set message recording time33

Use your built-in answering system 33
 New message indication33
 Message playback33
 Delete all old messages 34
 Record, play and delete memos.....35
 Message window displays 36
 Remote access36
 Set your remote access code37
 Call screening37
 Call intercept.....37

Use the built-in answering system and voicemail service..... 38

Retrieve voicemail from telephone service . 38
 Retrieve voicemail..... 38
 Turn off the new voicemail indicators..... 38

Screen messages..... 39

Expand your telephone system..... 41

General product care..... 41

Frequently asked questions..... 42

For C-UL compliance only44

The RBRC seal..... 47

FCC, ACTA and IC regulations 47

California Energy Commission battery charging testing instructions.....49

Limited warranty..... 50

Disclaimer and Limitation of Liability 51

Technical specifications 52

What's in the box

Your telephone package contains the following items. Save your sales receipt and original packaging in the event warranty service is necessary.

NOTE

To purchase replacement batteries or power adapters, visit our website at www.vtechphones.com or call 1 (800) 595-9511. In Canada, go to phones.vtechcanada.com or dial 1 (800) 267-7377.

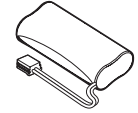

1 set for LS6425/LS642V-1E/LS642V-1F/LS642V-1G

2 sets for LS6425-2
 3 sets for LS6425-3/LS6426-3
 4 sets for LS6425-4/LS6426-4

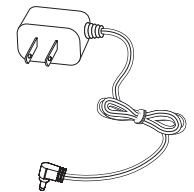
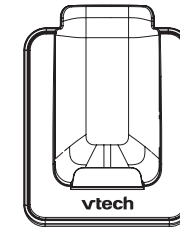
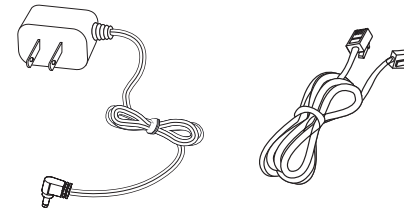
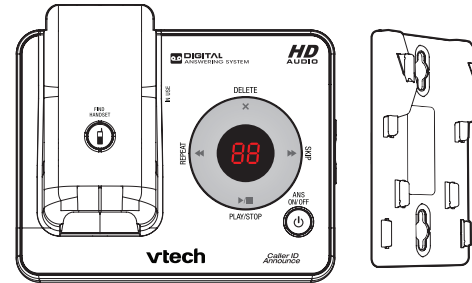

1 set for LS6425-2
 2 sets for LS6425-3/LS6426-3
 3 sets for LS6425-4/LS6426-4

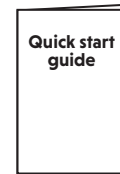

1 set for LS6425/LS6425-2/LS6425-3/
 LS6425-4/LS6426-3/LS6426-4/
 LS642V-1E/LS642V-1F/LS642V-1G

Overview

Telephone base overview

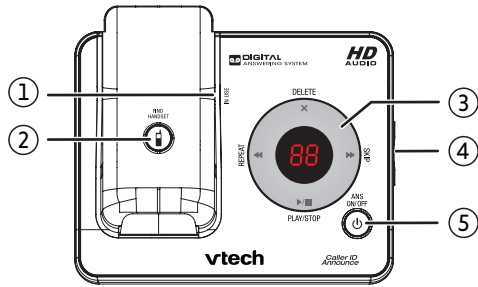

1 – IN USE light

- Flashes when there is an incoming call, or another telephone sharing the same line is in use.
- Flashes when the handsets are being deregistered.
- On when the handset is in use, or the answering system is answering a call.
- On when a handset is being registered.

2 – /FIND HANDSET

- Page all system handsets.

3 – /REPEAT

- Repeat a message.
- Press twice to play the previous message.

X/DELETE

- Delete the message currently playing.
- Press twice to delete all old messages when the telephone is not in use.

/SKIP

- Skip to the next message.

/PLAY/STOP

- Play messages.
- Stop message playback.

Message window

- Shows the number of messages and other answering system information.

4 – /VOL/▼

- Press to adjust the speaker volume during message playback.
- Press to adjust the telephone base ringer volume when the telephone is not in use

5 – /ANS ON/OFF

- Turn the answering system on or off.

Handset overview

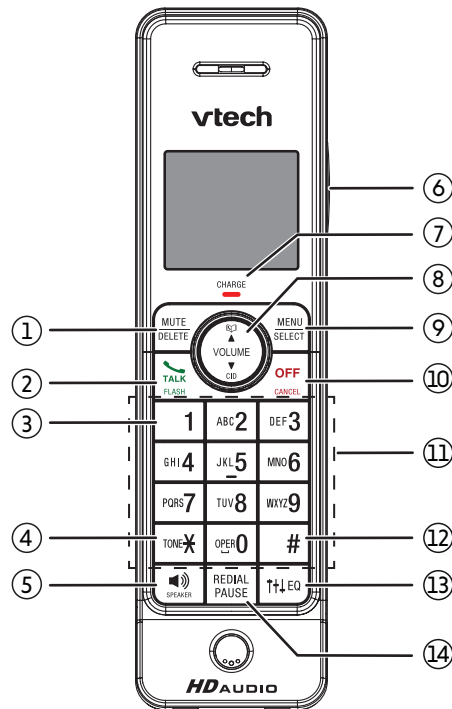

1 – MUTE/DELETE

- Mute the microphone during a call.
- Delete the displayed entry while in the directory, caller ID log or redial list.
- Silence the handset ringer temporarily while the phone is ringing.

- Delete digits or characters when entering numbers or names.

2 – /TALK/FLASH

- Make or answer a call.
- Answer an incoming call when you receive a call waiting alert.

3 – 1

- Press repeatedly to add or remove 1 in front of the caller ID log entry before dialing or saving it to the directory.

4 – TONE

- Switch to tone dialing temporarily while on a call.

5 – /SPEAKER

- Make or answer a call using the handset speakerphone.
- Switch between the handset speakerphone and the handset earpiece during a call.

6 – PUSH TO TALK (PTT)

- Press to begin a broadcast to one or multiple handsets.
- Press and hold to broadcast to a group of handsets when the handset is not in use.

7 – CHARGE light

- On when the handset is charging.

8 – /▲/VOLUME

- Review the directory when the telephone is not in use.
- Scroll up while in a menu, or in the directory, caller ID log or redial list.
- Move the cursor to the right when entering numbers or names.
- Increase the listening volume during a call or message playback.

CID/▼/VOLUME

- Review the caller ID log when the telephone is not in use.

- Scroll down while in a menu, or in the directory, caller ID log or redial list.
- Move the cursor to the left when entering numbers or names.
- Decrease the listening volume during a call or message playback.

9 – MENU/SELECT

- Show the menu.
- While in a menu, press to select an item, or save an entry or setting.

10 – OFF/CANCEL

- Hang up a call.
- Return to the previous menu or press and hold to exit menu display without making changes.
- Delete digits while predialing.
- Silence the handset ringer temporarily while the phone is ringing.
- Press and hold to erase the missed call indicator while the handset is not in use.

11 – Dialing keys

- Enter numbers or characters.

OPER 0

- Enter space character during text editing.

12 – # (pound key)

- Press repeatedly to show other dialing options when reviewing a caller ID log entry.
- Switch the name order when saving the caller ID log entries to the directory.









13 – EQ

- Change the audio quality to best suit your hearing during an outside call, intercom call, message or announcement playback.

14 – REDIAL/PAUSE

- Review the redial list.
- **Press and hold** to insert a dialing pause while dialing or entering numbers into the directory.

Display icons overview

	The battery icon flashes when the battery is low and needs charging.
	The battery icon animates when the battery is charging.
	The battery icon becomes solid when the battery is fully charged.
	The speakerphone is in use.
	The handset ringer is turned off.
	There are new voicemail received from your telephone service provider.
ANS ON	The answering system is turned on.
	There are new answering system messages.
NEW	New caller ID log entry.
MUTE	The microphone is muted.
	The message number currently playing and total number of messages recorded.

Telephone base lights overview

IN USE	<ul style="list-style-type: none"> • On when the telephone line is in use. • On when the answering system is answering a call. • On when you are registering a handset. • Flashes quickly when there is an incoming call. • Flashes when another telephone sharing the same line is in use. • Flashes when you are deregistering all handsets.
 /ANS ON/OFF	<ul style="list-style-type: none"> • On when the answering system is turned on.

Handset lights overview

	On when the handset speakerphone is in use.
CHARGE	On when the handset is charging in the telephone base or charger.

Connect

You can choose to connect the telephone base for desktop usage or wall mounting.

NOTE

- Use only the adapters provided.
- Make sure the electrical outlets are not controlled by wall switches.
- The adapters are intended to be correctly oriented in a vertical or floor mount position. The prongs are not designed to hold the plug in place if it is plugged into a ceiling, under-the-table or cabinet outlet.

TIP

- If you subscribe to digital subscriber line (DSL) high-speed Internet service through your telephone line, make sure you install a **DSL filter** (not included) between the telephone line cord and telephone wall jack. Contact your DSL service provider for more information.

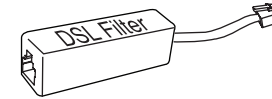

Connect the telephone base

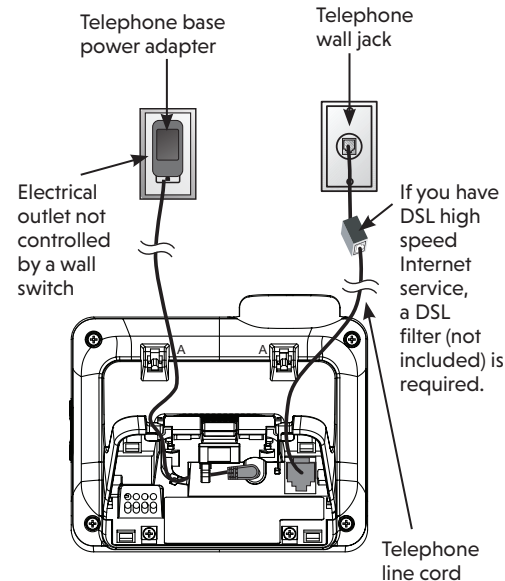

Connect the charger

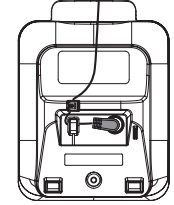
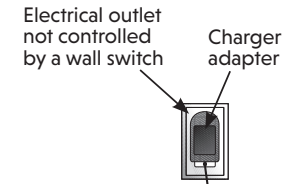

Mount the telephone base

Tabletop to wall mount installation

Your telephone base is ready for tabletop use. If you want to mount your telephone on a wall, use the provided wall mount bracket to connect with a standard dual-stud telephone wall mounting plate. If you do not have this mounting plate, you can purchase one from many hardware or consumer electronics retailers. You may need a professional to install the mounting plate.

1. Plug one end of the telephone line cord into the **TEL LINE** jack on the bottom of the telephone base. Plug the small end of the power adapter into the **POWER** jack on the bottom of the telephone base.

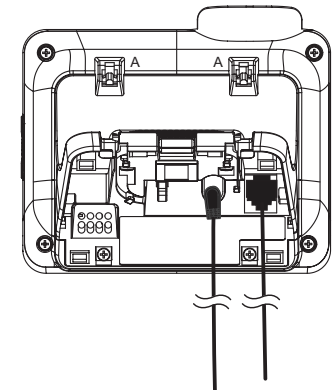

- Position the lower portion grooves on the telephone base to the lower portion tabs (marked **A**) on the wall mount bracket. Make sure the upper portion grooves of the telephone base are above the upper portion tabs on the wall mount bracket.

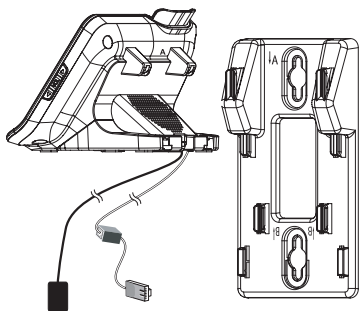

- Route the telephone line cord through the wall mount bracket hole and plug it into the telephone wall jack. Route the power cord out of the bottom of the telephone and plug it into an electrical outlet not controlled by a wall switch.

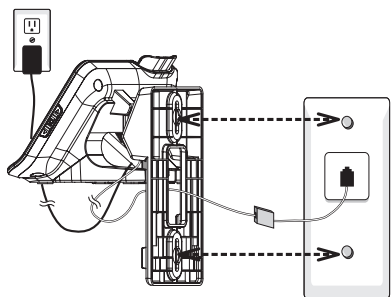

- Align the holes on the bracket with the standard wall plate and slide the bracket down until it locks securely. Bundle the telephone line cord and power adapter cord neatly with twist ties.

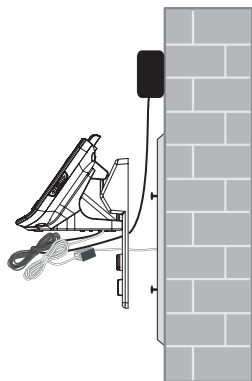

Wall mount to tabletop installation

- If the telephone line cord and power adapter cord are bundled, untie them first.
- Push the black wall mount bracket up and remove it from the wall plate. Unplug the telephone line cord (or DSL filter) from the wall. Unplug the power adapter from the power outlet.
- Push the wall mount bracket down to remove it from the telephone base.

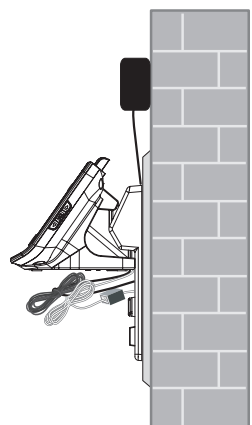

Install the battery

Install the battery as shown below.

NOTES

- Use only supplied battery.
- Charge the battery provided with this product only in accordance with the instructions and limitations specified in this manual.
- If the handset will not be used for a long time, disconnect and remove the battery to prevent possible leakage.

- Plug the battery connector securely into the socket inside the handset battery compartment, matching the color-coded label.

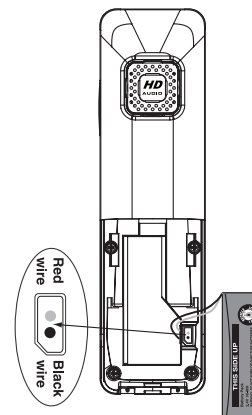

- Place the battery with the label **THIS SIDE UP** facing up and the wires inside the battery compartment.

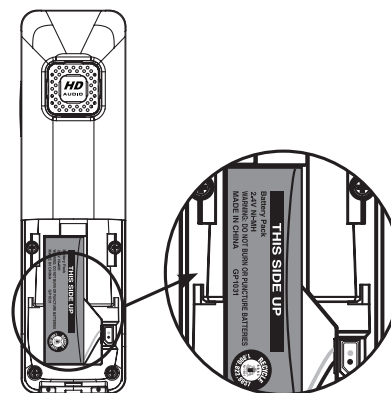

- Slide the battery compartment cover towards the center of the handset until it clicks into place.

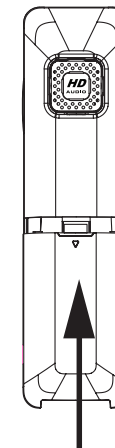

Check the battery level

After you have installed the battery, check the battery level on the handset screen.

- If the battery icon is or or , then go to **Before use** section to set the date and time.
- If the screen is blank, or flashes, then the battery needs to be charged. Go to **Charge the battery** section below before you do any setting or operation.

Charge the battery

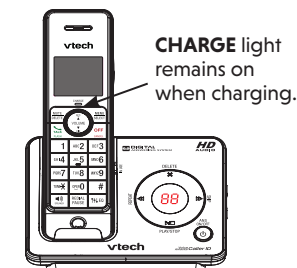

Place the handset in the telephone base or the charger to charge.

Once you have installed the battery, the handset LCD display indicates the battery status (see the table on the next page).



NOTES

- Press **CANCEL** or place the handset in the charger will bypass the set date and time.
- For best performance, keep the handset in the telephone base or charger when not in use.
- The battery is fully charged after 10 hours of continuous charging.
- If you place the handset in the telephone base or the charger without plugging in the battery, the screen displays **No battery**.

Battery indicators	Battery status	Action
The screen is blank, or displays Place in charger and  flashes.	The battery has no or very little charge. The handset cannot be used.	Charge without interruption (at least 30 minutes).
The screen displays Low battery and  flashes.	The battery has enough charge to be used for a short time.	Charge without interruption (about 30 minutes).
The screen displays HANDSET X .	The battery is charged.	To keep the battery charged, place it in the telephone base or charger when not in use.

When the battery is fully charged, you can expect the following performance:

Operation	Operating time
While in use (talking*)	Up to seven hours
While in speakerphone mode (talking*)	Up to five hours
While not in use (standby**)	Up to seven days

* Operating times vary depending on your actual use and the age of the battery.



** Handset is not charging nor in use.

Before use

After you install your telephone or power returns following a power outage, the handset will prompt you to set the date and time (see **Set date and time**). To skip setting the date and time, press **OFF/CANCEL**. To manually set the date and time, refer to **Configure your telephone** section.



Set date and time

1. Use the dialing keys (**0-9**) to enter the month (**MM**), date (**DD**) and year (**YY**). Then press **SELECT**.
2. Use the dialing keys (**0-9**) to enter the hour (**HH**) and minute (**MM**). Then press  or  to choose **AM** or **PM**.
3. Press **SELECT** to save.

Check for dial tone

Press . If you hear a dial tone, the installation is successful.



If you do not hear a dial tone:

- Make sure the installation procedures described above are properly done.
- It may be a wiring problem. If you have changed your telephone service to digital service from a cable company or a VoIP service provider, the telephone line may need to be rewired to allow all existing telephone jacks to work. Contact your cable/VoIP service provider for more information.

Operating range

This cordless telephone operates with the maximum power allowed by the Federal Communications Commission (FCC). Even so, this handset and telephone base can communicate over only a certain distance - which can vary with the locations of the telephone base and handset, the weather, and the layout of your home or office.



When the handset is out of range, the handset displays **Out of range OR No pwr at base**.

If there is a call while the handset is out of range, it may not ring, or if it does ring, the call may not connect well when you press . Move closer to the telephone base, then press  to answer the call.

If the handset moves out of range during a telephone conversation, there may be interference. To improve reception, move closer to the telephone base.





Configure your telephone

Use the handset menu

1. Press **MENU/SELECT** when the phone is not in use.
2. Press  or  until the screen displays the desired feature menu.
3. Press **MENU/SELECT**.
 - To return to the previous menu, press **OFF/CANCEL**.
 - To exit menu display, press and hold **OFF/CANCEL**.

Set date and time

The answering system announces the date and time of each message prior to playing it. Before using the answering system, set the date and time as follows. If you subscribe to caller ID service, the day, month and time are set automatically with each incoming call. However, the year must be correct so that the day of the week can be calculated from the caller ID information. You can also turn off the date and time settings of the caller ID service (see **CID time synchronization**) and set the date and time manually.

1. Press **MENU/SELECT** on the handset when not in use.
2. Press  or  to choose **Set date/time** and then press **MENU/SELECT**.
3. Use the dialing keys (**0-9**) to enter the month (**MM**), date (**DD**) and year (**YY**). Then press **MENU/SELECT**.
4. Use the dialing keys (**0-9**) to enter the hour (**HH**) and minute (**MM**). Then press  or  to choose **AM** or **PM**.
5. Press **MENU/SELECT** to save your setting. You hear a confirmation tone.

NOTES

- If the date and time are not set when a message is recorded, the system announces, "Time and date not set," before each message plays.
- The telephone plays two beeps if you enter an invalid number.

Set LCD language

The LCD language is preset to English. You can select English, French or Spanish to be used in all screen displays.

1. Press **MENU/SELECT** when the handset is not in use.
2. Press ▼ or ▲ to choose **Settings** and then press **MENU/SELECT**.
3. Press **MENU/SELECT** again to choose **LCD language**.
4. Press ▼ or ▲ to choose **English, Français** or **Español**.
5. Press **MENU/SELECT** to save your setting. You hear a confirmation tone.

Set voice language

You can select English or French to be used for the voice prompts in your answering system or caller ID announce feature. The voice language is preset to English.

1. Press **MENU/SELECT** when the handset is not in use.
2. Press ▼ or ▲ to choose **Settings** and then press **MENU/SELECT**.
3. Press ▼ or ▲ to choose **Voice language** and then press **MENU/SELECT**.
4. Press ▼ or ▲ to choose **Answering sys** or **Caller ID annc**, and then press **MENU/SELECT**.
5. Press ▼ or ▲ to choose **English** or **Français**.
6. Press **MENU/SELECT** to save your setting. You hear a confirmation tone.

Caller ID announce

The caller ID announce feature lets you know who's calling without having to look at the display. When you have an incoming call, the handset and/or base announces the caller's name based on the directory or caller ID information. If the caller's name is private or unknown, the phone number will be announced. If the caller's phone number is also private or unknown, no caller information will be announced. If the telephone number has over 11 digits, only the last 11 digits will be announced. Unless you change it, the caller ID announce feature is already turned on.

1. Press **MENU/SELECT** when the handset is not in use.
2. Press ▼ or ▲ to choose **Settings** and then press **MENU/SELECT**.
3. Press ▼ or ▲ to choose **Annc Caller ID** and then press **MENU/SELECT**.
4. Press ▼ or ▲ to choose **HANDSET** or **BASE** and then press **MENU/SELECT**.
5. Press ▼ or ▲ to choose **On** or **Off**.
6. Press **MENU/SELECT** to save your setting. You hear a confirmation tone.

NOTES

- To use the caller ID announce feature, you must subscribe to caller ID service from your telephone service provider.
- Caller ID announce is available in English only.
- The caller ID announce is muted when you turn the ringer off.
- Only the first four registered handsets are able to use the caller ID announce feature.
- It takes at least 2 rings for the phone to receive caller ID information and announce it. If the phone is answered before the end of the second ring, it will not have time to announce the caller ID information.
- Pronunciation of names may vary with this feature. Not all names may be pronounced correctly.

CID time synchronization

This feature allows the time and date to be set by incoming caller ID information. The default setting is **On**.

1. Press **MENU/SELECT** on the handset when not in use.
2. Press ▼ or ▲ to choose **Settings** and then press **MENU/SELECT**.
3. Press ▼ or ▲ to choose **CID time sync** and then press **MENU/SELECT**.
4. Press ▼ or ▲ to choose **On** or **Off**.
5. Press **MENU/SELECT** to save your setting. You hear a confirmation tone.

Dial mode

The dial mode is preset to touch-tone dialing. If you have pulse (rotary) service, you need to change the dial mode to pulse dialing before using the telephone.

1. Press **MENU/SELECT** when the handset is not in use.
2. Press ▼ or ▲ to choose **Settings**, and then press **MENU/SELECT**.
3. Press ▼ or ▲ to choose **Dial mode**, then press **MENU/SELECT**.
4. Press ▼ or ▲ to choose **Tone** or **Pulse**, then press **MENU/SELECT** to confirm your selection. You hear a confirmation tone.

NOTE

- While on a call in pulse dialing mode, press **TO**  **NE** to temporarily change to tone dialing mode.

Telephone operations

Handset control key panel:

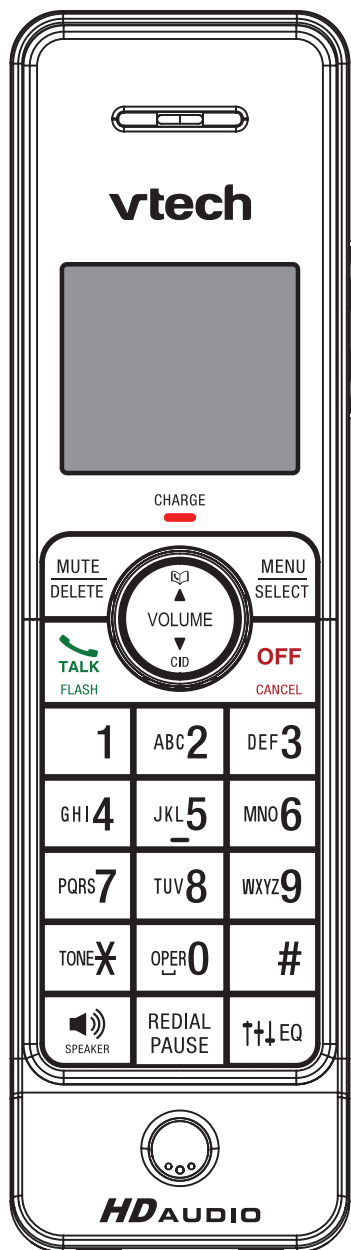

Make a call

- Press **TALK/FLASH** or **SPEAKER**, and then dial the telephone number.

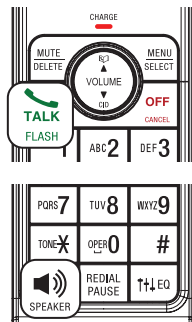

NOTES

- The screen shows the elapsed time as you talk (in hours, minutes and seconds).
- While entering numbers, press and hold **REDIAL/PAUSE** to insert a dialing pause (a **P** appears).

Predial a call

- Enter the telephone number using the dialing keys (**0-9**), then press **TALK/FLASH** or **SPEAKER** to dial.

NOTES

- When predialing (preview numbers before dialing), press **MUTE/DELETE** or **OFF/CANCEL** to backspace and delete; press and hold **REDIAL/PAUSE** to insert a dialing pause (a **P** appears).
- The handset displays **Unable to call. Line in use** if you predial a number while your telephone line is in use.

Answer a call

- Press **TALK/FLASH**, **SPEAKER** or any of the dialing key (**0-9**, **#** or **TONE***).

End a call

- Press **OFF/CANCEL** or put the handset back in the telephone base or charger.

Speakerphone

During a call, press **SPEAKER** to switch between speakerphone and normal handset use.

When the speakerphone is active, the handset displays **Speaker** and **SPEAKER**.

Listening volume

- During a call, press **VOLUME** or **VOLUME** to adjust the listening volume.

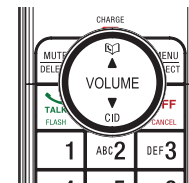

Mute

The mute function allows you to hear the other party but the other party cannot hear you.

- During a call, press **MUTE/DELETE**. The handset displays **Muted** for a few seconds and **MUTE** displays until the mute function is turned off.
- Press **MUTE/DELETE** again to resume the conversation. The handset screen temporarily displays **Microphone ON**.

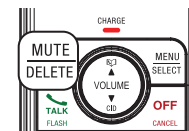

Temporary ringer silencing

When the telephone is ringing, press **OFF/CANCEL** or **MUTE/DELETE** to temporarily silence the ringer on that handset only. The handset displays **Ringer muted** and **Ringer muted**. This turns off the ringer without disconnecting the call. The next call rings normally at the preset volume.

NOTE

- Each handset rings when there is an incoming call unless the ringer volume is turned off on that handset.

Temporary tone dialing

If you have pulse (rotary) service only, you can switch from pulse to touch-tone dialing temporarily during a call. This is useful if you need to send touch-tone signals to access your telephone banking or long distance services.

- During a call, press **TONE*** on the handset.
- Use the dialing keys to enter the number. The telephone sends touch-tone signals. It automatically returns to pulse dialing mode after you end the call.

Find handset

The find handset feature helps you find misplaced handsets.

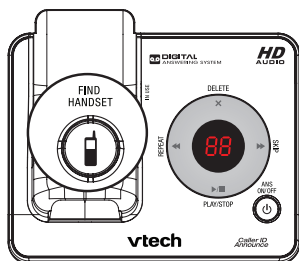

To start paging:

- Press **FIND HANDSET** on the telephone base when not in use. All idle handsets ring and display **** Paging ****.

To end paging:

- Press **FIND HANDSET** on the telephone base.
- OR-** Press **TALK/FLASH**, **SPEAKER** or any dialing key (**0-9**, **#** or **TONES**) on the handset.

NOTES

- Press **OFF/CANCEL** or **MUTE/DELETE** to temporarily turn off the paging tone on the handset. Its screen shows **Ringer muted** and .
- All registered handsets ring when being paged even if the ringer volume is set to off.
- Do not press and hold **FIND HANDSET** for more than four seconds. It may lead to handset deregistration. If the handset displays **Put HS on BASE to register**, refer to the **Frequently asked questions** section to register the handset back to the telephone base.

Call waiting

When you subscribe to call waiting service from your telephone service provider, you hear an alert tone if there is an incoming call while you are already on a call.

- Press **TALK/FLASH** to put the current call on hold and take the new call.
- Press **TALK/FLASH** at any time to switch back and forth between calls.

If you also subscribe to caller ID service, it will let you see the name and telephone number of the caller during call waiting.

It may be necessary to change your telephone service to use this feature. Contact your telephone service provide if:

- You have both caller ID and call waiting, but as separate service (you may need to combine these service);
- You have only caller ID service, or only call waiting service; or
- You do not subscribe to caller ID or call waiting services.

There are fees for caller ID services. In addition, services may not be available in all areas.

Equalizer

The equalizer feature on the handset enables you to change the audio quality of the handset to best suit your hearing.

While on a call or intercom call, or listening to a message or announcement, press **EQ** to select the equalizer setting **Treble 1**, **Treble 2**, **Bass** or **Natural** (the default setting) for the handset. The current setting is displayed on the handset briefly.

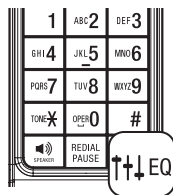

Chain dialing

Use this feature to initiate a dialing sequence from numbers stored in the directory, caller ID log or redial list while you are on a call.

Chain dialing can be useful if you wish to access other numbers (such as bank account numbers or access codes) from the directory, caller ID log or redial list.

To access a number in the directory while on a call:

- Press **MENU/SELECT**.
- Press **▼** or **▲** to highlight **Directory**, and then press **MENU/SELECT**.
- Press **▼** or **▲** to scroll to the desired entry.
- Press **MENU/SELECT** to dial the displayed number.

To access a number in the caller ID log while on a call:

- Press **MENU/SELECT**.
- Press **▼** or **▲** to highlight **Caller ID log**, then press **MENU/SELECT**.
- Press **▼** or **▲** to scroll to the desired entry.
- Press **MENU/SELECT** to dial the displayed number.

To access a number in the redial list while on a call:

- Press **REDIAL/PAUSE** to enter the redial list.
- Press **▼**, **▲** or **REDIAL/PAUSE** repeatedly to browse to the desired entry.
- Press **MENU/SELECT** to dial the displayed number.

Redial list

Each handset stores the last 10 telephone numbers dialed. Entries are shown in reverse chronological order. When there are already 10 entries, the oldest entry is deleted to make room for the new entry. When you access the redial list with no records, the handset plays two beeps and shows **Redial empty**.

Review a redial list entry

- Press **REDIAL/PAUSE** when the handset is not in use to enter the redial list.
- Press **▼**, **▲** or **REDIAL/PAUSE** repeatedly until the desired entry displays.



Dial a redial list entry

- Press **REDIAL/PAUSE** when the handset is not in use to enter the redial list.
- Press **▼**, **▲** or **REDIAL/PAUSE** repeatedly until the desired entry displays.
- Press **TALK/FLASH** or **SPEAKER** to dial.

-OR-

- Press **TALK/FLASH** or **SPEAKER** when the phone is not in use.
- Press **REDIAL/PAUSE** and then press **▼**, **▲** or **REDIAL/PAUSE** repeatedly until the desired entry displays.
- Press **MENU/SELECT** to dial.

Delete a redial list entry

- Press **REDIAL/PAUSE** when the handset is not in use.
- Press **▼**, **▲** or **REDIAL/PAUSE** repeatedly to browse to the desired entry.
- Press **MUTE/DELETE** to delete the displayed number. You hear a confirmation tone.

Copy a number from the redial list to the directory

1. Press **REDIAL/PAUSE** when the handset is not in use.
2. Press **▼**, **▲** or **REDIAL/PAUSE** repeatedly to browse to the desired entry, then press **MENU/SELECT**. The screen displays **EDIT NUMBER**.
3. Use the dialing keys (**0-9**) to edit the number (up to 30 digits).
 - Press **MUTE/DELETE** to backspace and delete a digit.
 - Press and hold **MUTE/DELETE** to delete all digits.
 - Press **▼** or **▲** to move the cursor to the left or right.
 - Press and hold **REDIAL/PAUSE** to insert a dialing pause (a **p** appears).
4. Press **MENU/SELECT** to move on to the name. The screen displays **ENTER NAME**.
5. Use the dialing keys to enter a name (up to 15 characters).
 - Press **0** to add a space.
 - Press **MUTE/DELETE** to backspace and delete a character.
 - Press and hold **MUTE/DELETE** to delete all characters.
 - Press **▼** or **▲** to move the cursor to the left or right.
6. Press **MENU/SELECT** to save the entry. The handset shows **Saved** and you hear a confirmation tone.

Multiple handset use

Join a call in progress (for multiple handset models only)

The telephone base supports four system handsets at a time on an outside call. You can buy additional expansion handsets (**LS6405/LS640V**) for this telephone base. You can register up to 12 handsets to the telephone base.

To share an outside call:

- When a handset is already on a call, press **TALK/FLASH** or **SPEAKER** on another handset to join the call.
- To exit the call, press **OFF/CANCEL** or place the handset in the telephone base or charger. The call continues until all handsets hang up.

Intercom

Use the intercom feature for conversations between two handsets. This feature is available only if you have two or more handsets.

1. When the handset is not in use, press **MENU/SELECT**. Press **▼** or **▲** to highlight **Intercom**, then press **MENU/SELECT**.
- OR -
Press **TALK/FLASH** or **SPEAKER**, then press **MENU/SELECT**. Press **▼** or **▲** to highlight **Intercom**, then press **MENU/SELECT**.
 - If you have two handsets, your handset displays **Calling other handset**.
 - If you have more than two handsets, your handset displays **INTERCOM TO:**. Use the dialing keys to enter a handset number (**1-9** for handsets 1-9, **TONE X** and **0** for handset 10, **TONE X** and **1** for handset 11, **TONE X** and **2** for handset 12 or **TONE X** and **#** for all handsets), or press **▼** or **▲** to scroll to the desired handset then press **MENU/SELECT**. Your handset displays **Calling HANDSET X (X** represents the destination handset number) or **Calling all handsets**.
The other handset rings and its screen displays **Other handset is calling** or **HANDSET Y** is calling (**Y** represents the originating handset number).
2. To answer the intercom call, press **TALK/FLASH**, **SPEAKER** or any dialing key (**0-9**, **#** or **TONE X**) on the destination handset. Both handsets now display **Intercom**.
3. To end the intercom call, either party presses **OFF/CANCEL** or places the handset back in the telephone base or charger. Both handsets now display **Intercom ended**.

NOTES

- To cancel the intercom call before it is answered, press **OFF/CANCEL**.
- If the other handset does not answer the intercom call within 100 seconds, or if it is accessing the answering system, is out of range, or has no power, your handset displays **No answer. Try again** and returns to idle.
- Only one intercom call can be established with two handsets at a time.

Answer an incoming call during an intercom call



If you receive an incoming outside call during an intercom call, there will be an alert tone.

- To answer the outside call, press  **FLASH** on the handset. The intercom call ends automatically.
- To end the intercom call without answering the outside call, press **OFF/CANCEL**. The telephone continues to ring.

Transfer a call

Use the intercom feature to transfer an outside call to another system handset.

1. When the handset is on a call, press **MENU/SELECT**.
2. Press  or  to scroll to **Intercom**, then press **MENU/SELECT**. The outside call is put on hold automatically.
 - If you have two handsets, your handset displays **Calling other handset**.
 - If you have more than two handsets, your handset displays **INTERCOM TO:**. Use the dialing keys to enter a handset number (1-9 for handsets 1-9,  and 0 for handset 10,  and 1 for handset 11,  and 2 for handset 12 or  and # for all handsets), or press  or  to scroll to the desired handset then press **MENU/SELECT**. Your handset displays **Calling HANDSET X (X represents the destination handset number) or Calling all handsets**.
3. To answer the intercom call, press  or any dialing key (0-9, # or ) on the destination handset. Both handsets now display **Intercom**. You can now have a private conversation between the two handsets.

4. From this intercom call, you have the following options:
 - To transfer the call, press **MENU/SELECT** twice on the originating handset to choose **Transfer**. The originating handset displays **Call transferred**. The destination handset is automatically connected to the outside call.
 - To share the call, press **MENU/SELECT** on your handset and then press  or  to highlight **Share call**. Then press **MENU/SELECT**. Both handsets are connected to the outside call.
5. To end the outside call, press **OFF/CANCEL** or place the handset back in the telephone base or charger. The call continues until all handsets hang up.

NOTES



- You can cancel the intercom call before it is answered by pressing **OFF/CANCEL**.
- If the destination handset does not answer the intercom call within 100 seconds, or if it is accessing the answering system, is out of range, or has no power, the originating handset displays **No answer. Try again** and returns to idle.

Blind transfer

Use this feature to transfer an outside call to other system handsets without notifying them. This feature is available only if you have two or more handsets.

1. When the handset is on a call, press **MENU/SELECT**.
2. Press **MENU/SELECT** to choose **Transfer**.
 - If you have two handsets, your handset displays **Transferring call....**
 - If you have more than two handsets, your handset displays **TRANSFER TO:**. Use the dialing keys to enter a handset number (1-9 for handsets 1-9,  and 0 for handset 10,  and 1 for handset 11,  and 2 for handset 12 or  and # for all handsets), or press  or  to scroll to the desired handset then press **MENU/SELECT**. Your handset displays **Transferring call... or Transferring call to all...**
3. To answer the outside call, press  or any dialing key (0-9, # or ) on the destination handset.
4. To end the outside call, press **OFF/CANCEL** or place the handset back in the telephone base or charger.

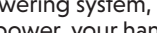
NOTES

- To cancel the blind transfer and return to the external call before it is answered, press **OFF/CANCEL** on your handset.
- If the destination handset does not answer the transferring call within 30 seconds, is accessing the answering system, is out of range, or has no power, your handset rings back and displays **No response to transfer**. If you do not press  or any dialing key (0-9, # or ) on your handset to reconnect the outside call within 30 seconds, the call hangs up automatically.





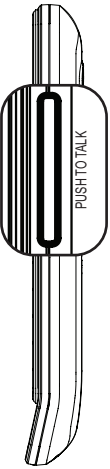

Push-to-talk (PTT)

You can directly broadcast messages from one handset to the speakerphone of one or multiple handsets. Press and hold **PUSH TO TALK** to begin two-way communication. If only one handset is available or registered, the handset screen shows **PTT requires two handsets** when you press **PUSH TO TALK**.



- Only one handset can talk at a time. To do so, press and hold **PUSH TO TALK** while you are talking.
- You must release **PUSH TO TALK**, so the other person can respond.
- Only one PTT session can be active at a time.
- While PTT is in use between two handsets, other handsets cannot use the intercom feature.
- If you attempt to place a PTT call to another handset that is on an outside call or intercom call, or accessing the answering system, your handset displays **Not available at this time**.

Turn PTT on or off

1. Press **PUSH TO TALK** when the handset is not in use. The **PUSH TO TALK** menu displays.
2. Press  or  to highlight **PTT On/Off**, then press **MENU/SELECT**.
3. Press  or  to choose **On** or **Off**, then press **MENU/SELECT**.

NOTE

- When PTT is turned off, the handset shows **No Incoming PTT** while the phone is not in use.

PTT to a single handset

1. You have two ways to begin a PTT call:
 - If you have two handsets, press and hold **PUSH TO TALK** when the handset is not in use.
 - If you have more than two handsets, press **PUSH TO TALK** when the handset is not in use. Then use the dialing keys to enter a handset number (**1-9** for handsets 1-9, ^{tone}**X** and **0** for handset 10, ^{tone}**X** and **1** for handset 11, ^{tone}**X** and **2** for handset 12 or ^{tone}**X** and **#** for all handsets), or press **▼** or **▲** to scroll to the desired handset then press **MENU/SELECT**. Press **MENU/SELECT** or **PUSH TO TALK** to create the push-to-talk session.

Your handset displays **Connecting to HANDSET X...** for a few seconds. When the connection is made, both the originating and the destination handsets display **Press and hold [PTT] to talk** and beep once.

2. Press and hold **PUSH TO TALK** on your handset. A chirp indicates your microphone is on. Speak towards the handset. Your voice is broadcast to the destination handset. While you are speaking, your handset displays **PTT To handset X** (X represents the destination handset).
3. Release **PUSH TO TALK** after speaking. Both handsets beep once again. After the handsets beep, you can press and hold **PUSH TO TALK** to continue speaking or the destination handset can respond (see **Answer a PTT call**).
4. Press **OFF/CANCEL** to end the PTT call. The handset displays **Push to talk Ended** for a few seconds.
-OR-
Place the handset in the telephone base or charger to end the PTT call.



NOTE

- After **PUSH TO TALK** is released, the PTT call remains open for a short time. If no one presses **PUSH TO TALK** within 10 seconds, the PTT call ends automatically.

PTT to a multiple handsets

When you have two to five registered handsets, PTT supports one-to-all calls (one-to-four maximum). However, when you have six or more registered handsets, PTT supports a maximum of one-to-three calls. The first four registered handsets will be able to use this feature. Other handsets can only use PTT for one-to-one calls.

1. To begin a PTT call to multiple handsets:
 - Press and hold **PUSH TO TALK** when the handset is not in use.
 - If you have more than two handsets, press **PUSH TO TALK** when the handset is not in use. Press ^{tone}**X** and **#**, or **▼** or **▲** to highlight **All handsets**, then press **MENU/SELECT** or **PUSH TO TALK**.

Your handset displays **Connecting to all handsets...** for a few seconds. When the connection is made, all handsets display **Press and hold [PTT] to talk** and beep once.

2. Press and hold **PUSH TO TALK** on your handset. A chirp indicates your microphone is on. Speak towards the handset. Your voice is broadcast to all destination handsets. While you are speaking, your handset displays **PTT To handset X** (X represents the destination handset).
3. Release **PUSH TO TALK** after speaking. Both handsets beep once again. After the handsets beep, you can press and hold **PUSH TO TALK** to speak again or the destination handsets can respond (see **Answer a PTT call**).

4. Press **OFF/CANCEL** to end the PTT call. The handset displays **Push to talk Ended** for a few seconds.
-OR-
Place the handset in the telephone base or charger to end the PTT call.



NOTE

- After **PUSH TO TALK** is released, the PTT call session remains open for a short time. If no one presses **PUSH TO TALK** within 10 seconds, the PTT call session ends automatically.

Answer a PTT call

You can respond to a PTT call whenever the speakerphone light is off, as described below.

1. When your handset receives a PTT call, the handset beeps and the screen displays **Press and hold [PTT] to talk**.
2. When the other party is speaking, your speakerphone light is on, and your handset displays **PTT From HS X To HS Y** (X represents the originating handset and Y represents the destination handset; a maximum of four handset numbers appear).
3. When your speakerphone light is off and the screen displays **Press and hold [PTT] to talk**, press and hold **PUSH TO TALK** on your handset. You will hear a chirp. Speak towards the handset.
 - While you are speaking, your handset displays **PTT To handset: X** (X represents the handset numbers of one or more destination handsets; a maximum of four handset numbers appear).
 - Your voice is broadcast to all destination handsets.

After speaking, release **PUSH TO TALK**. Your handset will beep. After the beep, if your speakerphone light is off, you can press and hold **PUSH TO TALK** to speak again or the destination handset can respond.

Change a one-to-one PTT call to intercom call

You can convert a one-to-one PTT session to an intercom call.

1. When your handset displays **Press and hold [PTT] to talk**, press **MENU/SELECT**. The screen displays **Intercom**.
2. Press **MENU/SELECT**.
 - If you have two handsets, your handset displays **Calling other handset**. The destination handset temporarily displays **Push to talk Ended** and then **Other handset is calling**.
 - If you have more than two handsets, your handset displays **Calling HANDSET Y** (Y represents the destination handset). The destination handset temporarily displays **Push to talk Ended** and then **Handset X is calling** (X represents the originating handset).
3. On the destination handset, press **TALK/FLASH, (SPEAKER)** or any dialing key (**0-9**, **#** or ^{tone}**X**) to answer the intercom call. Both handsets now display **Intercom**.
4. To end the intercom call, press **OFF/CANCEL** or place the handset in the telephone base or charger. Both screens display **Intercom ended**.

End a PTT call

- For a one-to-one PTT call, both the originating and destination handsets can end the PTT call.
- For a PTT call to multiple handsets, the originating handset can end the PTT call. If any one of the destination handsets leaves the PTT call, the call continues until all handsets hang up.

To end or leave a PTT call

- Press **OFF/CANCEL** or place the handset in the telephone base or charger. The handset displays **Push to talk Ended**.



NOTE

- After **PUSH TO TALK** is released, the PTT call session remains open for a short time. If no one presses **PUSH TO TALK** within 10 seconds, the PTT call session ends automatically.

Answer an incoming call during a PTT call

When you receive an incoming outside call during PTT, there is an alert tone.

- During a one-to-one PTT call, press **TALK/FLASH** on the originating or destination handset. The PTT call ends automatically and the outside call is answered.
- During a PTT call to multiple handsets, press **TALK/FLASH** on the originating handset. The PTT call ends automatically and the outside call is answered.
- During a PTT call to multiple handsets, press **TALK/FLASH** on any one of the destination handsets and that handset answers the outside call. The PTT call continues for the rest of the PTT participants.
- To leave the PTT call without answering the incoming call, press **OFF/CANCEL**. The telephone continues to ring.

Make an outgoing call during a PTT call

- During a one-to-one PTT call, press **TALK/FLASH** to get a dial tone. The PTT call ends automatically.
- During a PTT call to multiple handsets, press **TALK/FLASH** on the originating handset. The PTT call ends automatically and you get a dial tone.
- During a PTT call to multiple handsets, press **TALK/FLASH** on any one of the destination handsets and that handset gets a dial tone. The PTT call continues for the rest of the PTT participants.

Directory

The directory can store up to 50 entries with up to 30 digits for each phone number and 15 alphanumeric characters for each name.

- Directory entries are shared by all system handsets. Any additions, deletions or edits made on one handset are reflected on all handsets.
- When you access the directory with no records, the screen displays **Directory empty**.
- When the directory is full and you try to save an entry, the screen displays **Directory full**.
- When you try to save a number already stored in the directory, the screen displays **Number already saved**.
- When the telephone number in the directory exceeds 15 digits, while reviewing the directory, < * appears in front of the telephone number. Press **TONE X** to move towards the end of the telephone number or press # (pound key) to move towards the beginning of the telephone number.
- Only one handset can review the directory at a time. If a handset tries to enter the directory while another handset is already in it, **Not available at this time** appears.

Add a directory entry

Use the following steps to store an entry in the directory.

1. Enter the number when the phone is not in use. Press **MENU/SELECT**. The screen displays **EDIT NUMBER**.
-OR-
 - a. Press **MENU/SELECT** when the phone is not in use.
 - b. Press **▼** or **▲** to highlight **Directory**, then press **MENU/SELECT**.

- c. Press **▼** or **▲** to highlight **Add contact**, then press **MENU/SELECT**. The screen displays **ENTER NUMBER**.

2. Use the dialing keys to enter or modify the number.
-OR-
Copy a number from the redial list by pressing **REDIAL/PAUSE** and then press **▼**, **▲** or **REDIAL/PAUSE** repeatedly to select a number. Press **MENU/SELECT** to copy the number.
3. Press **MENU/SELECT** to move on to enter the name. The handset displays **ENTER NAME**.
4. Use the dialing keys to enter the name. Additional key presses show other characters of that particular key. Press the key repeatedly until the desired character appears. The first character and the character after a space are automatically capitalized.
5. Press **MENU/SELECT** to save. The screen displays **Saved** and you hear a confirmation tone.

```
Answering sus
>Directory
```

```
Review
>Add contact
```

```
ENTER NUMBER
800-595-9511
```

```
ENTER NAME
Mike Smith
```

Review a directory entry

Entries are sorted alphabetically.

1. Press  when the phone is not in use.
2. Press ▼ or ▲ to browse through the directory, or use the dialing keys to start a name search.



-OR-

1. Press **MENU/SELECT** when the phone is not in use.
2. Press ▼ or ▲ to scroll to **Directory** and then press **MENU/SELECT**.
3. Press **MENU/SELECT** again to choose **Review**.
4. Press ▼ or ▲ to browse.



Alphabetical search

1. Follow the steps in **Review a directory entry** to enter the directory.
2. Use the dialing keys to enter the letter associated with the name. For example, if you have entries for Jenny, Jessie, Kristen and Laura in your directory, press **5** (JKL) once to see Jenny (when **Jenny** displays, press ▼ to see Jessie), twice to see Kristen, or three times to see Laura. If there is no name entry matching your search, the next closest match in alphabetical order appears. If necessary, press ▼ or ▲ to browse.

Dial a directory entry

1. Search for the desired entry in the directory (see **Review a directory entry** or **Alphabetical search**).
2. When the desired entry appears, press /**FLASH** or /**SPEAKER** to dial.

-OR-

1. Press /**FLASH** or /**SPEAKER**.
2. Press **MENU/SELECT**.
3. Press ▼ or ▲ to highlight **Directory** and then press **MENU/SELECT**.
4. Press ▼ or ▲ or start an alphabetical search to browse to the desired entry, then press **MENU/SELECT** to dial the displayed number.

Edit a directory entry

1. Search for the desired entry in the directory (see **Review a directory entry** or **Alphabetical search**).
2. When the desired entry appears, press **MENU/SELECT**. The handset displays **EDIT NUMBER**.
3. Use the dialing keys to edit the number.
 - Press **MUTE/DELETE** to backspace and delete a digit.
 - Press and hold **MUTE/DELETE** to delete all digits.
 - Press ▼ or ▲ to move the cursor to the left or right.
4. Press **MENU/SELECT**. The handset displays **EDIT NAME**.
5. Use the dialing keys to edit the name. Additional key presses show other characters of that particular key. Press the key repeatedly until the desired character appears. The first character and the character after a space are automatically capitalized.
 - Press **0** to add a space.
 - Press **MUTE/DELETE** to backspace and delete a character.

- Press and hold **MUTE/DELETE** to delete all characters.
 - Press ▼ or ▲ to move the cursor to the left or right.
6. Press **MENU/SELECT** to save. The screen displays **Saved** and then the revised entry.

Delete the directory entries

1. Search for the desired entry in the directory (see **Review a directory entry** or **Alphabetical search**).
2. When the desired entry appears, press **MUTE/DELETE**. The handset displays **Delete contact?**.
3. Press **MENU/SELECT** to confirm. The handset displays **Contact deleted**. Then you hear a confirmation tone.

Speed dial

Assign a directory entry to a speed dial location

You can store up to 10 directory entries in the speed dial directory. The speed dial entries are shared by all handsets.

1. Press and hold an empty speed dial key (**0-9**).
 - OR-**
 - a. Press **MENU/SELECT** when the handset is not in use.
 - b. Press ▼ or ▲ to scroll to **Directory** and then press **MENU/SELECT**.
 - c. Press ▼ or ▲ to scroll to **Speed dial**, then press **MENU/SELECT**.
 - d. Press ▼ or ▲ to select an empty speed dial location.
2. Press **MENU/SELECT**. The screen displays **Copy from Directory...**
3. Press ▼ or ▲ to select a desired directory entry.
 - OR -**
 - Use the dialing keys to start an alphabetical search (see **Alphabetical search**).
4. Press **MENU/SELECT** to save. You hear a confirmation tone.

NOTE

- If the speed dial location is occupied, the new entry replaces the old one.

Dial a speed dial entry

Press and hold a speed dial key (**0-9**) of the desired entry when the handset is not in use, the number will be dialed automatically.

NOTE

- When the speed dial location chosen is empty, the handset will prompt you to the speed dial list. See **Assign a directory entry to a speed dial location** above to assign entries to the speed dial locations.

Reassign a speed dial number

1. Press **MENU/SELECT** when the phone is not in use.
2. Press **▼** or **▲** to highlight **Directory**, then press **MENU/SELECT**.
3. Press **▼** or **▲** to highlight **Speed dial**, then press **MENU/SELECT**.
4. Press **▼** or **▲** to select a desired speed dial location, then press **MENU/SELECT**.
5. Press **MENU/SELECT** to choose **Change SD**.
6. Press **MENU/SELECT** and then the screen displays **Copy from Directory...**
7. Press **▼** or **▲** to select a desired directory entry.
- OR -
Use the dialing keys to start an alphabetical search (see **Alphabetical search**).
8. Press **MENU/SELECT** to save. You hear a confirmation tone.

Delete a speed dial entry

1. Press **MENU/SELECT** when the phone is not in use.
2. Press **▼** or **▲** to highlight **Directory**, then press **MENU/SELECT**.
3. Press **▼** or **▲** to highlight **Speed dial**, then press **MENU/SELECT**.
4. Press **▼** or **▲** to highlight a desired speed dial location.
5. Press **MUTE/DELETE** to clear the speed dial location.
- OR -
Press **MENU/SELECT** twice. Press **▼** or **▲** to scroll to **Clear SD**, then press **MENU/SELECT**. The screen displays **Speed dial empty**. You hear a confirmation tone.

NOTE

- Clearing the speed dial locations does not affect the entries in the directory.

Caller ID

If you subscribe to caller ID service, information about each caller appears after the first or second ring. If you answer a call before the caller information appears on the screen, it will not be saved in the caller ID log.

The caller ID log stores up to 50 entries. Each entry has up to 24 digits for the phone number and 15 characters for the name.

If the telephone number has more than 15 digits, only the last 15 digits appear. If the name has more than 15 characters, only the first 15 characters are shown and saved in the caller ID log.

Entries appear in reverse chronological order. When the caller ID log is full, the oldest entry is deleted to make room for new incoming call information.

Caller ID log entries are shared by all system handsets. Any deletions made on one handset are reflected on all other handsets.

NOTE

- This product can provide information only if both you and the caller are in areas offering caller ID service and if both telephone service providers use compatible equipment. The time and date are sent by your telephone service provider along with the call information.

Review a caller ID log entry

1. Press **CID/▼** when the phone is not in use.
2. Press **▼** or **▲** to browse through the caller ID log.

-OR-

1. Press **MENU/SELECT** when the phone is not in use.
2. Press **▼** or **▲** to select **Caller ID log**, then press **MENU/SELECT**.
3. Press **MENU/SELECT** to select **Review**.
4. Press **▼** or **▲** to browse. You hear a double beep when you reach the beginning or end of the caller ID log.

Memory match

When the incoming telephone number matches the last seven digits of a telephone number in your directory, the screen displays the stored name of the directory entry.

For example, if Linda Jones calls, her name appears as **Linda** if this is how you entered it into your directory.

NOTE

- The number shown in the caller ID log is in the format sent by the telephone service provider. It usually delivers 10-digit telephone numbers (area code plus phone number). If the last seven digits of the incoming telephone number does not match a number in your directory, the name appears as it is delivered by the telephone service provider.

Missed call indicator

When there are calls that have not been reviewed in the caller ID log, the handset displays **XX Missed calls**. When you have reviewed all the missed calls, the missed call indicator no longer displays.

Each time you review a caller ID log entry marked **NEW**, the number of missed calls decreases by one.

If you do not want to review the missed calls one by one, press and hold **OFF/CANCEL** on the idle handset to erase the missed call indicator. All the entries are then considered old.

View dialing options

The caller ID log entries received have 10 digits (the area code plus the seven-digit number). You may dial a **1** plus the area code plus the seven digits.

While reviewing the caller ID log, press **#** (pound key) repeatedly if you need to add or remove **1** in front of the telephone number before dialing or saving it in the directory.



Press # →

1-800-595-9511
800-595-9511

NOTE

- 7-digit local dialing will be invalid from October 2021 onwards. Press **#** (pound key) repeatedly to select the appropriate dialing option.

Dial a caller ID log entry

1. Search for the desired caller ID entry (see **Review a caller ID log entry**).
2. When the desired entry displays, press /FLASH or /SPEAKER to dial.

Save a caller ID log entry to the directory

1. Search for the desired caller ID entry (see **Review a caller ID log entry**).
2. When the desired entry displays, press **MENU/SELECT**. The screen displays **EDIT NUMBER**.
3. Use the dialing keys to edit the number (up to 30 digits).
4. Press **MENU/SELECT** to move to the name. The screen displays **EDIT NAME**.
5. Use the dialing keys to edit the name (up to 15 characters).
6. Press **MENU/SELECT** to save the entry to the directory. The screen displays **Saved** and you hear a confirmation tone.

While entering names and numbers, you can:

- Press **MUTE/DELETE** to backspace and erase a digit or character.
- Press and hold **MUTE/DELETE** to erase the entire entry.
- Press **▼** or **▲** to move the cursor to the left or right.
- Press and hold **REDIAL/PAUSE** to insert a dialing pause (for entering numbers only).
- Press **0** to add a space (for entering names only).
- When entering names, press **#** (pound key) to switch the order of the names. For example, Miller Tom becomes Tom Miller when you press **#** (pound key).



NOTES

- If the name received from your telephone service provider is all in capital letters, the first letter of every word remains a capital letter. However, the next letter after prefix **Mac, Mc, D'** or **O'** is kept as a capital letter. For example, the **D** in **MacDonald** is kept as a capital letter. Another exception is that **VAN DER** will be changed to **Van der**.
- When you try to save a caller ID entry without any caller ID information, the handset displays **Unable to save**.

Delete the caller ID log entries

To delete one entry:

1. Search for the desired caller ID entry (see **Review a caller ID log entry**).
2. Press **MUTE/DELETE** to delete the selected entry.

To delete all caller ID log entries:

1. Press **MENU/SELECT** when the phone is not in use.
2. Press **▼** or **▲** to select **Caller ID log** and then press **MENU/SELECT**.
3. Press **▼** or **▲** to select **Del all calls**, then press **MENU/SELECT**. The screen displays **Delete all calls?**. Press **MENU/SELECT** to confirm. You hear a confirmation tone and the screen returns to the previous menu.

Caller ID log display screen messages

DISPLAYS:	WHEN:
PRIVATE NAME	The caller is blocking the name.
PRIVATE NUMBER	The caller is blocking the telephone number.
PRIVATE CALLER	The caller is blocking the name and number.
UNKNOWN NAME	This caller's name is unavailable.
UNKNOWN NUMBER	This caller's number is unavailable.
UNKNOWN CALLER	No information is available about this caller.

Sound settings

Key tone

You can adjust the key tone volume or turn it off for each handset. If you turn the key tone off, there are no beeps when you press the handset keys.

1. Press **MENU/SELECT** on the handset when not in use.
2. Press **▼** or **▲** to choose **Settings** and then press **MENU/SELECT**.
3. Press **▼** or **▲** to choose **Key tone** and then press **MENU/SELECT**.
4. Press **▼** or **▲** to select the desired volume or **Off**.
5. Press **MENU/SELECT** to confirm. You hear a confirmation tone.

Ringer tone

You can choose from different ringer tones for each handset.

1. Press **MENU/SELECT** when the handset is not in use.
2. Press **▼** or **▲** to choose **Ringers** and then press **MENU/SELECT**.
3. Press **MENU/SELECT** again to choose **Ringer tone**.
4. Press **▼** or **▲** to sample each ringer tone.
5. Press **MENU/SELECT** to save your setting. You hear a confirmation tone.



NOTE

- If you turn off the ringer volume, you will not hear ringer tone samples.

Ringer volume

You can set the ringer volume or turn the ringer off. When the ringer is off, **Ringer off** and  appear on the screen.

1. Press **MENU/SELECT** when the handset is not in use.
2. Press **▼** or **▲** to choose **Ringers** and then press **MENU/SELECT**.
3. Press **MENU/SELECT** again to choose **Ringer volume**.
4. Press **▼** or **▲** to sample each volume level.
5. Press **MENU/SELECT** to save your setting. You hear a confirmation tone.



NOTES

- The ringer volume also determines the ringer volume of intercom calls and paging tone. However, paging volume ranges from levels 4 to 6 only.
- If the ringer volume is set to off, the handset displays **Caller ID won't be announced** when you save the setting. The caller ID will not be announced when you have an incoming call (see **Caller ID announce**).

Telephone base ringer volume

Press **▲/VOL** or **▼/VOL** on the right side of the telephone base to adjust the ringer volume when the telephone is not in use. When you set the base ringer volume to off, the message window displays **0** and the system announces, "Base ringer is off." When the telephone is ringing, press **▼/VOL** to temporarily turn the base ringer off.

About the built-in answering system and voicemail service

For message recording, your telephone has a built-in answering system for each telephone line, and it also supports voicemail service offered by your telephone service provider (subscription is required, and fee may apply).

The main differences between them are:

CATEGORY	BUILT-IN ANSWERING SYSTEM	VOICEMAIL FROM TELEPHONE SERVICE
Storage	Messages are stored in the telephone base.	Messages are stored in a server or system provided by your telephone service provider.
	Your messages will not be deleted automatically. You have to delete your messages manually.	Your messages may be automatically deleted after a period of time. Contact your telephone service provider for more details.
Method to retrieve messages	When you received new messages, the handset screen displays OO and XX New messages , and the message window on the telephone base flashes.	When you received new messages, the handset displays ✉ and New voicemail .
	To retrieve messages: <ul style="list-style-type: none"> Press ▶/■ on the telephone base; or Press MENU on the handset, and then select Play messages; or Access remotely with an access code. 	To retrieve messages, you need an access number and/or a passcode provided by your telephone service provider.

Set your built-in answering system

The answering system can record and store up to 99 messages. The recording time of each message depends on the message length you set (see **Set message recording time**). The total storage capacity for the announcement, messages and memos is approximately 14 minutes. The actual recording time depends on individual message characteristics. Messages remain available for replay until you delete them.

Use the answering system menu of a system handset to turn on or off the answering system, set up the announcement message, activate the call screening, or change the number of rings, remote access code, message alert tone and message recording time. If your answering system is turned off and you change any of its settings, the answering system automatically turns on again.

You may also turn on or off the answering system at the telephone base.

Turn the answering system on or off

The answering system must be turned on to answer and record messages. When the answering system is turned on, the **⏻/ANS ON/OFF** light on the telephone base turns on and **ANS ON** displays on the handset.

To turn on or off with the telephone base:

Press **⏻/ANS ON/OFF** to turn the built-in answering system on or off. When the answering system is turned on, it announces, "Calls will be answered." When the answering system is turned off, it announces, "Calls will not be answered."

To turn on or off with a handset:

- Press **MENU/SELECT** when the handset is not in use.
- Press **▼** or **▲** to highlight **Answering sys**, then press **MENU/SELECT**.
- Press **▼** or **▲** to highlight **Answer ON/OFF**, then press **MENU/SELECT**.
- Press **▼** or **▲** to choose **On** or **Off**, then press **MENU/SELECT**.

NOTES

- When you turn on the answering system at the telephone base with no memory capacity left, the telephone announces, "Memory is full. Calls will not be answered," and the answering system cannot be turned on. When you turn on the answering system with a handset, the handset displays **Memory full**.
- If the memory capacity is less than 3 minutes, the telephone announces, "Less than 3 minutes to record," and the handset displays **Less than 3 min to record**.

Default announcement

The telephone is preset with a greeting that answers calls with "Hello, please leave a message after the tone." You can use this preset announcement, or replace it with your own.

Record your own announcement

You can record an announcement up to 90 seconds, but announcements shorter than two seconds will not be recorded.

- Press **MENU/SELECT** when the phone is not in use.
- Press **▼** or **▲** to select **Answering sys** and then press **MENU/SELECT**.

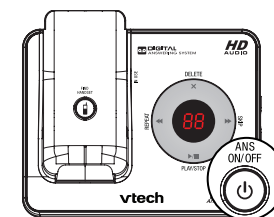

- Press **MENU/SELECT** to choose **Announcement**.
 - Press **▼** or **▲** to highlight **Record annnc**, then press **MENU/SELECT**. The system announces, "Record after the tone. Press 5 when you are done" and the screen shows **RECORDING ANNC... 5-Stop**.
 - After the tone, speak towards the handset microphone.
 - Press **5** when done. The answering system automatically plays back the newly recorded announcement, then returns to the previous menu.
- OR -
- Press **OFF/CANCEL** to exit without saving the recording.

Play your announcement

1. Press **MENU/SELECT** when the phone is not in use.
2. Press **▼** or **▲** to select **Answering sys** and then press **MENU/SELECT**.
3. Press **MENU/SELECT** to choose **Announcement**.
4. Press **MENU/SELECT** to choose **Play annnc**. The handset plays the announcement and the screen shows **PLAYING ANNC... 5-Stop**.
5. Press **5** to stop the playback and return to the previous menu or the handset screen automatically returns to the previous menu after the playback. Press **OFF/CANCEL** to return to the previous menu during playback.

Delete your announcement

1. Press **MENU/SELECT** when the phone is not in use.
2. Press **▼** or **▲** to select **Answering sys** and then press **MENU/SELECT**.
3. Press **MENU/SELECT** to choose **Announcement**.
4. Press **MENU/SELECT** to choose **Play annnc**.
5. When the handset is playing the announcement, press **MUTE/DELETE**. The handset displays **Annnc. Deleted** and announces, "Announcement deleted."

NOTE

- When your announcement is deleted, calls are answered with the preset announcement.

Set number of rings

You can choose from two, three, four, five, six rings or toll saver. With toll saver selected, the answering system answers after two rings when you have new messages, and after four rings when you have no new messages. This enables you to check for new messages and avoid paying unnecessary long distance charges if you are calling from out of your local area.

1. Press **MENU/SELECT** when the phone is not in use.
2. Press **▼** or **▲** to select **Answering sys** and then press **MENU/SELECT**.
3. Press **▼** or **▲** to select **Ans sys setup** and then press **MENU/SELECT**.
4. Press **▼** or **▲** to select **# of rings** and then press **MENU/SELECT**.
5. Press **▼** or **▲** to choose **6, 5, 4, 3, 2** or **Toll saver**, and then press **MENU/SELECT** to save.

NOTE

- If you set the number of rings that the answering system answers calls as 3 rings, the answering system may not have enough time to announce the caller's full information.

Turn the call screening on or off

Use this feature to choose whether incoming messages can be heard when they are being recorded.

To turn on or off with a handset:

1. Press **MENU/SELECT** when the phone is not in use.
2. Press **▼** or **▲** to select **Answering sys** and then press **MENU/SELECT**.
3. Press **▼** or **▲** to select **Ans sys setup** and then press **MENU/SELECT**.
4. Press **MENU/SELECT** to choose **Call screening**.
5. Press **▼** or **▲** to choose **On** or **Off**, and then press **MENU/SELECT** to save.

Turn the message alert tone on or off

The telephone base beeps every 10 seconds to alert you of new messages. The tone stops when all new messages have been reviewed.

1. Press **MENU/SELECT** when the phone is not in use.
2. Press **▼** or **▲** to select **Answering sys** and then press **MENU/SELECT**.
3. Press **▼** or **▲** to select **Ans sys setup** and then press **MENU/SELECT**.
4. Press **▼** or **▲** to select **Msg alert tone** and then press **MENU/SELECT**.
5. Press **▼** or **▲** to choose **On** or **Off**, then press **MENU/SELECT** to save.

NOTES

- The answering system must be turned on for the message alert tone to function.
- Press any key on the telephone base (except **⏏/FIND HANDSET**) to temporarily silence the message alert tone.

Set message recording time

You can set the recording time allowed for incoming messages. The message length is three minutes by default.

1. Press **MENU/SELECT** when the phone is not in use.
2. Press **▼** or **▲** to select **Answering sys** and then press **MENU/SELECT**.
3. Press **▼** or **▲** to select **Ans sys setup** and then press **MENU/SELECT**.
4. Press **▼** or **▲** to select **Recording time** and then press **MENU/SELECT**.
5. Press **▼** or **▲** to choose **3 minutes, 2 minutes** or **1 minute**, then press **MENU/SELECT** to save.

Use your built-in answering system

New message indication

The message window on the telephone base flashes and **XX New messages** displays on the handset when there are new answering system messages.

If the message alert tone is turned on, the telephone base beeps every 10 seconds when there are messages that have not been reviewed.

Message playback

If you have new messages, the telephone plays only the new messages (oldest first). If there are no new messages, the telephone plays back all messages (oldest first).

On the handset, if you have both new and old messages, you can play either new or old messages. The caller ID information displays on the handset screen when you play messages and you can call back the caller.

When playback begins, you hear the total number of messages followed by the day and time of the message. If the time and date are not set, the telephone announces, "Time and date not set." After the last message, the telephone announces, "End of messages."

To play message with the telephone base:

- Press **▶/■/PLAY/STOP** when the telephone is not in use.

Options during playback:

- Press **▼/VOL** or **▲/VOL** to adjust the speaker volume.
- Press **▶/SKIP** to skip to the next message.
- Press **◀/REPEAT** once to repeat the

message currently playing.

- Press **◀/REPEAT** twice to listen to the previous message.
- Press **X/DELETE** to delete the message currently playing. The system advances to the next message.
- Press **▶/■/PLAY/STOP** to stop. The telephone plays a long beep.

To play message with a handset:

1. Press **MENU/SELECT** when the phone is not in use.
2. Press **MENU/SELECT** to select **Play messages**. If you have either new or old messages, the messages play automatically. If you have both new and old messages:
 - To play new messages, press **MENU/SELECT** to select **Play new msgs**.
 - To play old messages, press **▼** or **▲** to highlight **Play old msgs**, then press **MENU/SELECT**.

When the handset is playing a message, its screen shows the caller's name or number. If the caller's information is unavailable, the handset shows **No caller info**.

Options during playback:

- Press **MENU/SELECT** to pause the playback, and display the caller's information, then press **TALK/FLASH** or **🔊/SPEAKER** to call back the caller. If you do not press **TALK/FLASH** within 10 seconds, message playback resumes automatically.
- Press **TALK/FLASH** to stop the playback and the screen displays **Call back?** then press **MENU/SELECT**, **TALK/FLASH** or **🔊/SPEAKER** to call back the caller.
- Press **▼/VOLUME** or **▲/VOLUME** to adjust the speaker volume.
- Press **↑↓ EQ** to adjust the handset message playback audio quality.

- Press **6** to skip to the next message.
- Press **4** once to repeat the message currently playing. Press **4** twice to listen to the previous message.
- Press **MUTE/DELETE** to delete the message currently playing. The system announces, "Message deleted," and advances to the next message.
- Press **5** to stop.

NOTES

- When the answering system has less than three minutes of recording time left, it announces, "Less than three minutes to record."
- When the telephone is not in use, if **F** and the number of messages are flashing alternately in the message window, or the handset displays **Rec mem full**, the memory is full. Delete some messages to make room for more.

Delete all old messages

To delete all old messages with the telephone base:

1. Press **X/DELETE** when the phone is not in use. The telephone announces, "To delete all old messages, press DELETE again."
2. Press **X/DELETE** again. All previously heard messages are deleted and the telephone announces, "All old messages deleted."

To delete all old messages with a handset:

1. Press **MENU/SELECT** when the handset is not in use.
2. Press **▼** or **▲** to highlight **Answering Sys**, then press **MENU/SELECT**.
3. Press **▼** or **▲** to highlight **Delete all old**, then press **MENU/SELECT**. The handset displays **Delete all old messages?**. If there are no old messages in the answering system, the handset displays **No old messages to delete**.

4. Press **MENU/SELECT** to save. The handset displays **Deleting...** and then **All old msgs deleted!** You hear a confirmation tone.

NOTE

- You can only delete old messages, which are messages you have played.

Record, play and delete memos

Memos are your own recorded messages used as reminders for yourself or others using the same answering system. You can record your own memos using a system handset. Play and delete them in the same way as incoming messages (see **Message playback**).

To record a memo:

1. Press **MENU/SELECT** when the phone is not in use.
2. Press **▼** or **▲** to select **Answering sys** and then press **MENU/SELECT**.
3. Press **▼** or **▲** to select **Record memo** and then press **MENU/SELECT**.
4. The system announces, "Record after the tone. Press 5 when you are done." After the tone, speak towards the handset microphone.
5. Press **5** when you finish recording. The system announces, "Recorded."

NOTES

- "Memory is full" is announced if you record a memo when the memory is full.
- Each memo can be up to four minutes in length.
- Memos shorter than two seconds are not recorded.

Message window displays

WINDOW DISPLAY	DESCRIPTION
0	No message.
1 - 99	The total number of old messages recorded. The message number currently playing.
0 - 99 (flashing)	When time and date are not set, it flashes 0, the total number of new messages recorded, or total number of old messages recorded. The telephone base may have lost and regained power. The clock needs to be set.
1 - 99 & F (alternating)	The answering system memory is full with total number of messages recorded.
1 - 8	The telephone base speaker volume level while adjusting.
0 - 6	The telephone base ringer level while adjusting.
.....	The system is answering a call, or recording a memo or announcement. The telephone is answering a call or being accessed remotely. The answering system is being programmed.

Remote access

A two-digit security code is required to access the answering system remotely from any touch-tone telephone. The preset code is **19**. You can use this preset code, or set your own.

1. Dial your telephone number from any touch-tone telephone.
2. When the system plays your announcement, enter the two-digit security code.
3. Enter one of the following remote commands.

COMMAND	DESCRIPTION
1	Play all messages.
2	Play only new messages.
3	Delete the current message (during playback).
33	Delete all old messages.
4	Repeat the current message (during playback).
44	Listen to the previous message (during playback).
5	Stop.
*5	Hear a list of remote commands.
6	Skip to the next message (during playback).
*7	Record a new announcement.
8	End the call.
0	Turn the answering system on or off.

4. Hang up or press **8** to end the call.

NOTES

- If you do not press any key after you enter the remote access code, all new messages play. If there are no new messages, all old messages play.
- Once the new messages have played, the telephone announces the help menu

options. If you do not press any key within 20 seconds, the remote access call automatically disconnects.

- When the answering system is turned off, the telephone answers after 10 rings, and announces, "Please enter your remote access code."
- When the memory is full, the answering system answers incoming calls after 10 rings and announces, "Memory is full. Enter your remote access code."

Set your remote access code

You can set your own remote access code from **00** to **99**.

1. Press **MENU/SELECT** when the phone is not in use.
2. Press **▼** or **▲** to select **Answering sys** and then press **MENU/SELECT**.
3. Press **▼** or **▲** to select **Ans sys setup** and then press **MENU/SELECT**.
4. Press **▼** or **▲** to select **Remote code** and then press **MENU/SELECT**.
5. Use the dialing keys (**0-9**) to enter a two-digit number, then press **MENU/SELECT** to save.

Call screening

Call screening at the telephone base:

If the answering system and call screening are on (see **Turn call screening on or off**), the announcement and the incoming message broadcast at the telephone base while the call is answered by the answering system.

Options while a message is being recorded:

- Press **▼/VOL** or **▲/VOL** on the telephone base to adjust the call screening volume.
- Press **▶/■/PLAY/STOP** to temporarily silence the call screening.
- Press **▶/■/PLAY/STOP** or **▲/VOL** to temporarily turn on the call screening if call screening is set to off.

Call screening at the handset:

If the answering system is on and your answering system is recording a message, your handset shows **To screen call, press [SELECT]**. Press **MENU/SELECT** to screen the call on your handset and the screen displays the caller ID information. If you do not subscribe to caller ID service, the handset shows **Screening...**

NOTE

- The call screening setting does not affect the call screening on the handset.

Call intercept

If you want to talk to the person whose message is being recorded, press

 **FLASH** or  **SPEAKER** on the handset.

Use the built-in answering system and voicemail service

You can use your answering system and voicemail service together by setting your answering system to answer before voicemail service answers as described below. To learn how to program your voicemail settings, contact your telephone service provider.

If you are on a call, or if the answering system is busy recording a message and you receive another call, the second caller can leave a voicemail message.

Set your answering system to answer calls at least two rings earlier than your voicemail service is set to answer. For example, if your voicemail service answers after six rings, set your answering system to answer after four rings. Some voicemail service providers may program the delay before answering calls in seconds instead of rings. In this case, allow six seconds per ring when determining the appropriate setting.

Retrieve voicemail from telephone service

Voicemail is a feature available from most telephone service providers. It may be included with your telephone service, or may be optional. Fees may apply.

Retrieve voicemail

When you received a voicemail, the handset displays  and **New voicemail**. To retrieve, you typically dial an access number provided by your telephone service provider, and then enter a security code. Contact your telephone service provider for instructions on how to configure the voicemail settings and listen to messages.

NOTE

- After you have listened to all new voicemail messages, the indicators on the handset turn off automatically.

Turn off the new voicemail indicators

Use the clear voicemail feature when the telephone indicates that there is new voicemail but there are none (for example, when you have accessed your voicemail while away from home). Clearing the voicemail waiting indicator only turns off the indicators; it does not delete your voicemail messages. As long as you have new voicemail messages, your telephone service provider continues to send the signal to turn on the indicators.

- Press **MENU** on the handset when not in use.
- Press **▼** or **▲** to choose **Settings** and then press **SELECT**.
- Press **▼** or **▲** to choose **Clr voicemail** and then press **SELECT**. The screen displays **Turn off indicator?**.
- Press **SELECT** to confirm. You hear a confirmation tone.

NOTES

- Your telephone service provider may alert you of new messages with a stutter (broken) dial tone. Contact your telephone service provider for details.
- Voicemail is different from answering system messages recorded in your cordless phone's answering system. For more information about the difference, see **About the built-in answering system and voicemail**.

Screen messages

Answering sys is ON	The answering system is automatically turned on when you change the settings under answering system setup menu.
Caller ID log empty	There are no caller ID log entries.
Calling HANDSET X (for models with three or more handsets)	You are calling another handset (for intercom calls).
Calling other handset (for models with two handsets)	
Directory empty	There are no directory entries.
Directory full	The directory is full.
Ended	You have just ended a call.
HANDSET X is calling (for models with three or more handsets)	Another handset is calling (for intercom calls).
Other handset is calling (for models with two handsets)	
Incoming call	There is an incoming call.
Intercom	The handset is on an intercom call.
Intercom ended	The intercom call has just ended.

Line in use	A system handset is in use, or another telephone on the same line is in use, or the answering system is answering a call.
Low battery	The battery needs to be recharged.
Microphone ON	MUTE is turned off and the person on the other end can hear you.
Muted	You have turned off the handset microphone. The other party cannot hear you but you can hear the other party.
New voicemail	There are new voicemail message(s) from the telephone service provider.
No answer. Try again	You have attempted to make an intercom call, but the handset you are calling is in the directory, in the caller ID log or out of range, or the handset you are calling is accessing the answering system or on an outside call.
No battery	No battery is installed. Follow the directions for battery installation on page 7 to install the battery before charging.
No line	There is no telephone line connected.
No signal, call ended	Communication between the handset and telephone base is lost during a call.

Not available at this time	One handset is already viewing the caller ID log or directory, and another handset attempts to review it. You attempt to place a PTT call to another handset which is on an outside call or intercom call, or accessing the answering system.
Number already saved	The telephone number you entered is already stored in the directory.
Out of range OR No fur at base	The handset cannot communicate with the telephone base. Check the telephone base power connection or move the handset closer to the telephone base.
** Paging **	The system handset is being paged.
Phone	The handset is on a call.
PRIVATE NAME	The caller is blocking the name information.
PRIVATE NUMBER	The caller is blocking the telephone number information.
PRIVATE CALLER	The caller is blocking the name and the telephone number information.
Place in charger	The battery is very low. Place the handset in the telephone base or charger for recharging.
Rec mem full	The answering system memory is full.
Rec mem low	The answering system has less than three minutes of recording time left.

Ringer muted	The ringer is muted temporarily during an incoming or intercom call.
Ringer off	The handset ringer is turned off.
Saved	Your selection has been saved.
Speaker	The handset speakerphone is in use.
Unable to call. Line in use	You are attempting to predial a number while the telephone line is in use.
Unable to call. Try again	You try to join a call when there are already four handsets on that call, or to make an outside call when another handset is transferring a call with the intercom feature.
Unable to save	You are attempting to save a caller ID entry without a name and number into the directory.
UNKNOWN NAME	This caller's name is unavailable.
UNKNOWN NUMBER	This caller's number is unavailable.
UNKNOWN CALLER	No caller information is available about this caller.
XX Missed calls	There are XX calls that have not been reviewed in your caller ID log.
XX New messages	There are XX new messages in the answering system.

Expand your telephone system

You can add new handsets (**LS6405/LS640V**, purchased separately) to your telephone base. Your telephone base supports a maximum of 12 handsets.

For more details, refer to the user's manual that comes with your **LS6405/LS640V** new handset.

General product care

Taking care of your telephone

Your cordless telephone contains sophisticated electronic parts, so it must be treated with care.

Avoid rough treatment

Place the handset down gently. Save the original packing materials to protect your telephone if you ever need to ship it.

Avoid water

Your telephone can be damaged if it gets wet. Do not use the handset outdoors in the rain, or handle it with wet hands. Do not install the telephone base near a sink, bathtub or shower.

Electrical storms

Electrical storms can sometimes cause power surges harmful to electronic equipment. For your own safety, take caution when using electrical appliances during storms.

Cleaning your telephone

Your telephone has a durable plastic casing that should retain its luster for many years. Clean it only with a dry non-abrasive cloth. Do not use dampened cloth or cleaning solvents of any kind.

Frequently asked questions

Below are the questions most frequently asked about the cordless telephone. If you cannot find the answer to your question, visit our website at

www.vtechphones.com or call

1 (800) 595-9511 for customer service. In Canada, visit phones.vtechcanada.com or

call 1 (800) 267-7377.

My telephone does not work at all.	Make sure the telephone base is installed properly, and battery is installed and charged correctly. For optimum daily performance, return the handset to the telephone base after use.
The display shows No line . I cannot hear the dial tone.	Disconnect the telephone line cord from your telephone and connect it to another telephone. If there is no dial tone on that other telephone either, then the telephone line cord may be defective. Try installing a new telephone line cord. If changing the telephone line cord does not help, the wall jack (or the wiring to this wall jack) may be defective. Contact your telephone service provider. You may be using a new cable or VoIP service, the existing telephone jacks in your home may no longer work. Contact your service provider for solutions.
The display shows Put HS on BASE to register . The handset does not work at all.	The handset is deregistered from the telephone base. Place the handset in the telephone base to register it back. The handset shows HANDSET X Registered (X) represents the registered handset number) and beeps when the registration process completes. This process takes about 90 seconds to complete.

I cannot dial out.	Make sure there is a dial tone before dialing. It is normal if the handset takes a second or two to synchronize with the telephone base before producing a dial tone. Wait an extra second before dialing. Eliminate any background noise. Mute the handset before dialing, or dial from another room in your home with less background noise.
The display shows Low battery .	Place the handset in the telephone base or charger for charging.
The battery does not charge in the handset or the handset battery does not accept charge.	Make sure the handset is placed in the telephone base or charger correctly. If the battery is completely depleted, charge the battery for at least 30 minutes before use. You may need to purchase a new battery.
The telephone does not ring when there is an incoming call.	Make sure the ringer volume is not set to off. The handset may be too far from the telephone base. Move it closer to the telephone base.
My handset beeps and is not performing normally.	Move the handset closer to the telephone base. It may be out of range.
I hear noise on the cordless handset and the keys do not work.	Make sure the telephone line cord is plugged in securely.
I hear other calls when using the telephone.	Disconnect the telephone base from the telephone wall jack. Plug in a different telephone. If you still hear other calls, the problem is probably in the wiring or telephone service. Contact your telephone service provider.

There is interference during a telephone conversation. My calls fade out when I am using the cordless handset.	The handset may be out of range. Move it closer to the telephone base. If you subscribe to high-speed Internet service (DSL - digital subscriber line) through your telephone line, you must install a DSL filter between the telephone line cord and the telephone wall jack. The filter prevents noise and caller ID problems caused by DSL interference. Contact your DSL service provider for more information about DSL filters.
	Appliances or other cordless telephones plugged into the same circuit as the telephone base can cause interference. Try moving the appliance or telephone base to another outlet.
	The location of your telephone base can impact the performance of your cordless phone. For better reception, install the telephone base in a centralized location within your home or office, away from walls or other obstructions. In many environments, elevating the telephone base improves overall performance.

The telephone does not receive caller ID or the telephone does not show caller ID during call waiting.	Caller ID is a subscription service. You must subscribe to this service from your telephone service provider for this feature to work on your telephone. Both your and the caller's telephone service providers must use equipment compatible with the caller ID service. The caller may not be calling from an area which supports caller ID. The caller ID information displays after the first or second ring.
	The handset may be out of range. Move it closer to the telephone base. Make sure the power cord is securely plugged into the telephone base. Use a working electrical outlet not controlled by a wall switch.
	I subscribe to a nontraditional telephone service that uses my computer to establish connections, and my telephone doesn't work. Make sure your computer is powered on, and your Internet is working properly. Make sure to plug your USB telephone adapter into a dedicated USB port on your computer. Do not plug into a multiple port USB hub (USB splitter) that is not powered. In a few rare instances, the USB port on your computer may not have enough power. In these instances, try using a USB hub with its own external power supply. If you are using a firewall, it may prevent access to your nontraditional telephone service. Contact your service provider for more information.

For C-UL compliance only

Mesures de sécurité importantes

Afin de réduire les risques d'incendie, de blessures corporelles ou d'électrocution, suivez toujours ces mesures préventives de base lorsque vous utilisez votre téléphone :



1. Lisez et comprenez bien toutes les instructions.
2. Observez toutes les instructions et mises en garde inscrites sur l'appareil.
3. Débranchez ce téléphone de la prise murale avant de le nettoyer. N'utilisez pas de nettoyeurs liquides ni en aérosol. N'utilisez qu'un chiffon doux et légèrement humecté.
4. **ATTENTION:** Ne pas installer le socle téléphonique à une hauteur supérieure à 2 mètres.
5. N'utilisez pas ce produit près de l'eau, tel que près d'un bain, d'un lavabo, d'un évier de cuisine, d'un bac de lavage ou d'une piscine, ou dans un sous-sol humide ou sous la douche.
6. Ne déposez pas ce téléphone sur un chariot, support ou table chancelants. L'appareil pourrait tomber et être sérieusement endommagé.
7. Évitez d'installer le système téléphonique dans les endroits soumis à une température extrême, à la lumière directe du soleil ou à proximité immédiate d'autres appareils électriques ou électroniques. Protégez votre téléphone contre les sources d'humidité, la poussière, les vapeurs et les liquides corrosifs.
8. Le boîtier de l'appareil est doté de fentes et d'ouvertures d'aération situées à l'arrière ou en dessous. Afin d'empêcher la surchauffe, ces ouvertures ne doivent pas être obstruées en plaçant l'appareil sur un lit, divan, tapis ou autre surface similaires. Ne placez pas cet appareil à proximité d'un élément de chauffage ni d'une plinthe électrique. De plus, ne l'installez pas dans une unité murale ou un cabinet fermé qui ne possède pas d'aération adéquate.
9. Ne faites fonctionner cet appareil qu'avec le type d'alimentation indiqué

sur les étiquettes de l'appareil. Si vous ne connaissez pas le voltage de votre maison, consultez votre marchand ou votre fournisseur d'électricité.

10. Ne déposez rien sur le cordon d'alimentation. Installez cet appareil dans un endroit sécuritaire, là où personne ne pourra trébucher sur la ligne d'alimentation ni le cordon téléphonique modulaire.
11. N'insérez jamais d'objets à travers les fentes et ouvertures de cet appareil, car ils pourraient toucher à des points de tension dangereux ou court-circuiter des pièces, ce qui constituerait un risque d'incendie ou d'électrocution. N'échappez pas de liquides dans l'appareil.
12. Afin de réduire les risques d'électrocution, ne démontez pas l'appareil, mais apportez-le plutôt à un centre de service qualifié s'il doit être réparé. En enlevant le couvercle, vous vous exposez à des tensions dangereuses ou autres dangers similaires. Un remontage inadéquat peut être à l'origine d'une électrocution lors d'une utilisation ultérieure de l'appareil. Débranchez l'appareil avant de procéder au nettoyage. Utilisez un chiffon humide et doux.
13. Ne surchargez pas les prises de courant et les rallonges.
14. Débranchez cet appareil de la prise de courant et communiquez avec le département de service à la clientèle de VTech dans les cas suivants :
 - Lorsque le cordon d'alimentation est endommagé ou écorché.
 - Si du liquide a été échappé dans l'appareil.
 - Si l'appareil a été exposé à une source d'humidité telle que la pluie ou l'eau.
 - Si le produit ne fonctionne pas normalement en respectant les instructions de fonctionnement. Réglez uniquement les commandes indiquées dans les instructions de fonctionnement. Les réglages incorrects des autres commandes pourraient provoquer un dommage qui pourrait exiger un travail exhaustif de la part d'un technicien autorisé afin

de rétablir le fonctionnement normal de l'appareil.

- Si le produit a été échappé et que le socle et/ou le combiné a été endommagé.
 - Si le produit affiche une nette diminution de sa performance.
15. Évitez d'utiliser un téléphone (autre qu'un sans fil) pendant un orage. Les éclairs peuvent être à l'origine d'une électrocution.
 16. N'utilisez pas le téléphone pour rapporter une fuite de gaz à proximité de la fuite. En certaines circonstances, une flammèche pourrait être provoquée lorsque l'adaptateur est branché à une prise de courant, ou lorsque le combiné est déposé sur le socle. Ceci est un événement commun associé à la fermeture d'un circuit électrique. L'utilisateur ne devrait pas brancher le téléphone à une prise de courant, et ne devrait pas déposer le combiné chargé sur le socle, si le téléphone se trouve à proximité d'un endroit comportant des concentrations de gaz inflammables, à moins que la ventilation soit adéquate. Une flammèche dans un tel endroit pourrait provoquer un incendie ou une explosion. De tels environnements peuvent comprendre: des endroits où l'on utilise de l'oxygène médical sans ventilation adéquate; des gaz industriels (dissolvants de nettoyage, des vapeurs d'essence, etc.); une fuite de gaz naturel, etc.
 17. Ne placez que le combiné de votre téléphone près de votre oreille lorsqu'en mode de conversation.
 18. Ces adaptateurs ont été conçus pour être orientés en position verticale ou montés au sol. Les broches ne sont pas conçues pour maintenir l'adaptateur en place si celui-ci est branché dans une prise au plafond ou sous une table/ armoire.
 19. Pour le MATERIEL RACCORDE PAR PRISE DE COURANT, le socle de prise de courant doit être installé à proximité du matériel et doit être aisément accessible.

20.   **MISE EN GARDE:** Il peut y avoir un risque d'explosion si vous utilisez le mauvais type de piles pour le téléphone. N'utilisez que les piles rechargeables incluses ou les piles de rechange. N'incinerez pas les piles. Celles-ci risqueraient d'exploser. Mettre au rebut les batteries usagées conformément aux instructions du fabricant. Débrancher les lignes téléphoniques avant le remplacement des piles.

- Évitez d'utiliser la batterie dans les conditions suivantes:
 - des températures extrêmes faibles ou élevées auxquelles une batterie peut être soumise pendant l'utilisation, le stockage ou le transport.
 - remplacement d'une batterie par un type incorrect pouvant supprimer une protection.
 - mise au rebut d'une batterie dans un feu ou dans un four chaud, ou écrasement mécanique ou coupure d'une batterie, susceptible de provoquer une explosion.
 - maintien d'une batterie dans un environnement à très haute température pouvant provoquer une explosion ou la fuite de liquide ou de gaz inflammables.
 - batterie soumise à une pression de l'air extrêmement faible pouvant provoquer une explosion ou la fuite de liquide ou de gaz inflammables.
- 21. N'utilisez que les adaptateurs inclus avec ce produit. L'utilisation d'un adaptateur dont la polarité ou la tension serait inadéquate risque d'endommager sérieusement le produit et mettre votre sécurité en péril.
- 22. La plaque signalétique appliquée est située au bas ou à proximité du produit.

CONSERVEZ CES INSTRUCTIONS

Pile

- N'utilisez que la pile incluse ou l'équivalent.

- Ne jetez pas la pile au feu. Vérifiez les instructions spécifiques de mise aux rebus auprès des autorités locales.
- N'ouvrez pas et ne mutiliez pas la pile. L'électrolyte qui s'en échapperait est corrosif et pourrait causer des brûlures ou des blessures aux yeux ou à la peau. L'électrolyte est toxique si avalé.
- Soyez prudents lorsque vous manipulez les piles afin d'éviter les courts-circuits provoqués par des matériaux conducteurs.
- Rechargez la pile incluse avec cet appareil, selon les instructions et limites spécifiées dans ce guide d'utilisation.

Stimulateurs cardiaques implantés dans l'organisme

Les simulateurs cardiaques (s'applique uniquement aux téléphones numériques sans fil) :

L'organisme 'Wireless Technology Research, LLC (WTR)', une firme de recherche indépendante, a mené une évaluation pluridisciplinaire des interférences entre les téléphones sans fil portatifs et les stimulateurs cardiaques implantés dans l'organisme. Appuyée par l'Administration des aliments et drogues (FDA) des États-Unis, la firme WTR recommande aux médecins :

Avis aux détenteurs de stimulateurs cardiaques

- Ils doivent tenir le téléphone sans fil à une distance d'au moins six pouces du stimulateur cardiaque.
- Ils ne doivent PAS placer le téléphone sans fil directement sur le stimulateur cardiaque, tel que dans une poche de chemise, lorsque celui-ci est en marche.
- Ils doivent utiliser le téléphone sans fil en l'appuyant sur l'oreille qui se trouve dans la direction opposée au stimulateur cardiaque.

L'étude effectuée par l'organisme WTR n'a pas identifié de risque pour les détenteurs de simulateurs cardiaques causés par les gens qui utilisent un téléphone sans fil à proximité de ceux-ci.

À propos des téléphones sans fil

Confidentialité : Les mêmes caractéristiques qui constituent des avantages pour les téléphones sans fil

affichent également des restrictions. Les appels téléphoniques sont transmis entre le combiné sans fil et le socle par le biais d'ondes radio ; il y a donc la possibilité que vos conversations téléphoniques sans fil soient interceptées par des équipements de réception radio se trouvant dans la portée du combiné sans fil. Pour cette raison, vous ne devez pas percevoir les communications téléphoniques sans fil comme étant aussi confidentielles que celles des téléphones à cordons.

Alimentation électrique : Le socle de ce téléphone sans fil doit être branché à une prise électrique fonctionnelle. La prise électrique ne doit pas être contrôlée par un interrupteur mural. Les appels ne pourront pas être effectués du combiné sans fil si le socle est débranché ou mis hors tension ou si le courant est coupé.

Possibilité d'interférences aux téléviseurs : Certains téléphones sans fil fonctionnent sur des fréquences pouvant causer des interférences aux téléviseurs et aux magnétoscopes. Pour réduire ou prévenir de telles interférences, ne placez pas le socle du téléphone sans fil près ou sur un téléviseur ou magnétoscope. S'il y a présence de parasites, il est conseillé d'éloigner le téléphone sans fil du téléviseur ou du magnétoscope afin de réduire possiblement les interférences.

Piles rechargeables : Manipulez les piles avec soin afin de ne pas les court-circuiter avec des bagues, bracelets ou clés. Les piles ou le conducteur peut surchauffer et causer des blessures. Respectez la polarité adéquate entre la pile et le chargeur.

Les bloc-piles rechargeables à l'hydrure métallique de nickel : Jetez ces blocs-piles de manière écologique et sécuritaire. Ne les incinerez pas et ne les percez pas. Tel que les autres piles de ce type, elles pourraient dégager une matière toxique qui peut causer des blessures corporelles si elles sont brûlées ou percées.

The RBRC seal

The RBRC seal on the nickel-metal hydride battery indicates that VTech Communications, Inc. is voluntarily participating in an industry program to collect and recycle these batteries at the end of their useful lives, when taken out of service within the United States and Canada.

The program provides a convenient alternative to placing used nickel-metal hydride batteries into the trash or municipal waste, which may be illegal in your area.

VTech's participation makes it easy for you to drop off the spent battery at local retailers participating in the program or at authorized VTech product service centers. Please call **1 (800) 8 BATTERY®** for information on Ni-MH battery recycling and disposal bans/restrictions in your area. VTech's involvement in this program is part of its commitment to protecting our environment and conserving natural resources.

The RBRC seal and 1 (800) 8 BATTERY® are registered trademarks of Call2recycle, Inc.



FCC, ACTA and IC regulations

FCC Part 15

NOTE: This equipment has been tested and found to comply with the requirements for a Class B digital device under Part 15 of the Federal Communications Commission (FCC) rules. These requirements are intended to provide reasonable protection against harmful interference in a residential installation. This equipment generates, uses and can radiate radio frequency energy and, if not installed and used in accordance with the instructions, may cause harmful interference to radio communications. However, there is no guarantee that interference will not occur in a particular installation. If this equipment does cause harmful interference to radio or television reception, which can be determined by turning the equipment off and on, the user is encouraged to try to correct the interference by one or more of the following measures:

- Reorient or relocate the receiving antenna.
- Increase the separation between the equipment and receiver.
- Connect the equipment into an outlet on a circuit different from that to which the receiver is connected.
- Consult the dealer or an experienced radio/TV technician for help.

WARNING: Changes or modifications to this equipment not expressly approved by the party responsible for compliance could void the user's authority to operate the equipment.

This device complies with Part 15 of the FCC rules. Operation is subject to the following two conditions: (1) this device may not cause harmful interference, and (2) this device must accept any interference received, including

interference that may cause undesired operation. Privacy of communications may not be ensured when using this telephone.

To ensure safety of users, the FCC/ISED has established criteria for the amount of radio frequency energy that can be safely absorbed by a user or bystander according to the intended usage of the product. This product has been tested and found to comply with the FCC/ISED criteria. The handset may be safely held against the ear of the user. The telephone base shall be installed and used such that parts of the user's body other than the hands are maintained at a distance of approximately 20 cm (8 inches) or more.

This Class B digital apparatus complies with Canadian requirement:

CAN ICES-3 (B)/NMB-3(B)

FCC Part 68 and ACTA

This equipment complies with Part 68 of the FCC rules and with technical requirements adopted by the Administrative Council for Terminal Attachments (ACTA). The label on the back or bottom of this equipment contains, among other things, a product identifier in the format US:AAAEQ##TXXXX. This identifier must be provided to your telephone service provider upon request. The plug and jack used to connect this equipment to premises wiring and the telephone network must comply with applicable Part 68 rules and technical requirements adopted by ACTA. A compliant telephone cord and modular plug is provided with this product. It is designed to be connected to a compatible modular jack that is also compliant. An RJ11 jack should normally be used for connecting to a single line and an RJ14 jack for two lines. See the installation instructions in the user's manual. The Ringer Equivalence Number (REN) is

used to determine how many devices you may connect to your telephone line and still have them ring when you are called. The REN for this product is encoded as the 6th and 7th characters following the US: in the product identifier (e.g., if ## is 03, the REN is 0.3). In most, but not all areas, the sum of all RENs should be five (5.0) or less. For more information, please contact your telephone service provider.

This equipment must not be used with Party Lines. If you have specially wired alarm dialing equipment connected to your telephone line, ensure the connection of this equipment does not disable your alarm equipment. If you have questions about what will disable alarm equipment, consult your telephone service provider or a qualified installer. If this equipment is malfunctioning, it must be unplugged from the modular jack until the problem has been corrected.

Replacement to this telephone equipment can only be made by the manufacturer or its authorized agents. For replacement procedures, follow the instructions outlined under the Limited warranty. If this equipment is causing harm to the telephone network, the telephone service provider may temporarily discontinue your telephone service. The telephone service provider is required to notify you before interrupting service. If advance notice is not practical, you will be notified as soon as possible. You will be given the opportunity to correct the problem and the telephone service provider is required to inform you of your right to file a complaint with the FCC. Your telephone service provider may make changes in its facilities, equipment, operation, or procedures that could affect the proper functioning of this product. The telephone service provider is required to notify you if such changes are planned.

If this product is equipped with a corded or cordless handset, it is hearing aid

compatible.

If this product has memory dialing locations, you may choose to store emergency telephone numbers (e.g., police, fire, medical) in these locations. If you do store or test emergency numbers, please:

Remain on the line and briefly explain the reason for the call before hanging up. Perform such activities in off-peak hours, such as early morning or late evening.

Industry Canada

This device contains licence-exempt transmitter(s)/receiver(s) that comply with Innovation, Science and Economic Development Canada's licence-exempt RSS(s). Operation is subject to the following two conditions:

- (1) This device may not cause interference.
- (2) This device must accept any interference, including interference that may cause undesired operation of the device.

Privacy of communications may not be ensured when using this telephone.

The term "IC:" before the certification/registration number only signifies that the Industry Canada technical specifications were met.



The Ringer Equivalence Number (REN) for this terminal equipment is 0.1. The REN indicates the maximum number of devices allowed to be connected to a telephone interface. The termination of an interface may consist of any combination of devices subject only to the requirement that the sum of the RENs of all the devices not exceed five.

This product meets the applicable Innovation, Science and Economic Development Canada technical specifications.

California Energy Commission battery charging testing instructions

This telephone is set up to comply with the energy-conserving standards right out of the box. These instructions are intended for California Energy Commission (CEC) compliance testing only. When the CEC battery charging testing mode is activated, all telephone functions, except battery charging, will be disabled.

To activate the CEC battery charging testing mode:

1. Unplug the telephone base power adapter from the power outlet. Make sure all handsets are plugged with charged batteries before proceeding.
2. While you **press and hold** /**FIND HANDSET**, plug the telephone base power adapter back to the power outlet.
3. After about 20 seconds, when the **IN USE** light starts flashing, release /**FIND HANDSET** and then press it again within 2 seconds. The process takes up to one minute to complete. When the phone successfully enters the CEC battery charging testing mode, the **IN USE** light turns off and all handsets display **Put HS on BASE to register**.

If the phone fails to enter this mode, repeat all the steps mentioned above. The telephone base will be powered up as normal if you fail to press /**FIND HANDSET** within two seconds in Step 3.

To deactivate the CEC battery charging testing mode:

1. Unplug the telephone base power adapter from the power outlet, then plug it back in. Then the telephone base is powered up as normal.
2. Place the handset in the telephone base to register it back. The handset displays **Registering... Please wait** and the red **IN USE** light on the telephone base turns on. If the registration is successful, the handset screen displays **HANDSET X registered** and beeps. The handset is registered with the telephone base.

Limited warranty

What does this limited warranty cover?

The manufacturer of this VTech Product warrants to the holder of a valid proof of purchase ("Consumer" or "you") that the Product and all accessories provided in the sales package ("Product") are free from defects in material and workmanship, pursuant to the following terms and conditions, when installed and used normally and in accordance with the Product operating instructions. This limited warranty extends only to the Consumer for Products purchased and used in the United States of America and Canada.

What will VTech Communications do if the Product is not free from material defects in materials and workmanship during the limited warranty period ("Materially Defective Product")?

During the limited warranty period, VTech's authorized service representative will replace at VTech's option, without charge, a Materially Defective Product. If we replace the Product, we may use new or refurbished replacement parts. If we choose to replace the Product, we may replace it with a new or refurbished Product of the same or similar design. We will retain defective parts, modules, or equipment. Replacement of the Product, at VTech's option, is your exclusive remedy. VTech will return the replacement Products to you in working condition. You should expect the replacement to take approximately 30 days.

How long is the limited warranty period?

The limited warranty period for the Product extends for ONE (1) YEAR from the date of purchase. If VTech replaces a Materially Defective Product under the terms of this limited warranty, this limited warranty also applies to the replacement Product for a period of either (a) 90 days from the date the replacement Product is shipped to you or (b) the time remaining on the original one-year warranty; whichever is longer.

What is not covered by this limited warranty?

This limited warranty does not cover:

1. Product that has been subjected to misuse, accident, shipping or other physical damage, improper installation, abnormal operation or handling, neglect, inundation, fire, water or other liquid intrusion; or
2. Product that has been damaged due to repair, alteration or modification by anyone other than an authorized service representative of VTech; or
3. Product to the extent that the problem experienced is caused by signal conditions, network reliability or cable or antenna systems; or
4. Product to the extent that the problem is caused by use with non-VTech electrical accessories; or
5. Product whose warranty/quality stickers, Product serial number plates or electronic serial numbers have been removed, altered or rendered illegible; or
6. Product purchased, used, serviced, or shipped for repair from outside the United States, or used for commercial or institutional purposes (including but not limited to Products used for rental purposes); or
7. Product returned without valid proof of purchase (see 2 below); or
8. Charges for installation or set up, adjustment of customer controls, and installation or repair of systems outside the unit.

How do you get warranty service?

To obtain warranty service in the United States of America, please visit our website at www.vtechphones.com or call 1 (800) 595-9511 for instructions regarding where to return the Product. In Canada, go to phones.vtechcanada.com or dial 1 (800) 267-7377.

NOTE: Before calling for service, please review the user's manual - a check of the

Product's controls and features may save you a service call.

Except as provided by applicable law, you assume the risk of loss or damage during transit and transportation and are responsible for delivery or handling charges incurred in the transport of Product(s) to the service location. VTech will return replaced product under this limited warranty to you, transportation, delivery or handling charges prepaid. VTech assumes no risk for damage or loss of the Product in transit.

What must you return with the Product to get warranty service?

1. Return the entire original package and contents including the Product to the VTech service location along with a description of the malfunction or difficulty;
2. Include "valid proof of purchase" (sales receipt) identifying the Product purchased (Product model) and the date of purchase or receipt; and
3. Provide your name, complete and correct mailing address, and telephone number.

Other limitations

This warranty is the complete and exclusive agreement between you and VTech. It supersedes all other written or oral communications related to this product. VTech provides no other warranties for this product. The warranty exclusively describes all of VTech's responsibilities regarding the product.

There are no other expressed warranties. No one is authorized to make modifications to this warranty and you should not rely on any such modification.

State Law Rights: This warranty gives you specific legal rights, and you may also have other rights which vary from state to state.

Limitations: Implied warranties, including those of fitness for a particular purpose and merchantability (an unwritten warranty

that the product is fit for ordinary use) are limited to one year from date of purchase. Some states do not allow limitations on how long an implied warranty lasts, so the above limitation may not apply to you.

In no event shall VTech be liable for any indirect, special, incidental, consequential, or similar damages (including, but not limited to lost profits or revenue, inability to use the product, or other associated equipment, the cost of substitute equipment, and claims by third parties) resulting from the use of this product. Some states do not allow the exclusion or limitation of incidental or consequential damages, so the above limitation or exclusion may not apply to you.

Please retain your original sales receipt as proof of purchase

Disclaimer and Limitation of Liability

VTech Communications, Inc. and its suppliers assume no responsibility for any damage or loss resulting from the use of this user's manual. VTech Communications, Inc. and its suppliers assume no responsibility for any loss or claims by third parties that may arise through the use of this product.

Company: VTech Communications, Inc.

Address: 9020 SW Washington Square Road - Ste 555 Tigard, OR 97223, United States

Phone: 1 (800) 595-9511 in the U.S. or 1 (800) 267-7377 in Canada

Technical specifications

Frequency control	Crystal controlled PLL synthesizer control
Transmit frequency	Handset: 1921.536-1928.448 MHz Telephone base: 1921.536-1928.448 MHz
Channels	DECT channel: 5
Nominal effective range	Maximum power allowed by FCC and IC. Actual operating range may vary according to environmental conditions at the time of use.
Power requirements	Handset: 2.4V Ni-MH battery Telephone base: DC 6V @ 0.4A Charger: DC 6V @ 0.4A
Memory	Directory: 50 memory locations; up to 30 digits and 15 characters Caller ID log: 50 memory locations; up to 24 digits and 15 characters



Specifications are subject to change without notice.
© 2023 VTech Communications, Inc. |
© 2023 VTech Technologies Canada Ltd.
All rights reserved. 01/23.
LS6425-X_WEB CIB_V8_230130

