

ANALOG CONTEMPORARY SERIES

CTM-A2415
Cordless 1-line Hotel Phone

CTM-A2415HC
Cordless Accessory Handset and Charging Base

vtech[®]

Master User 's Guide



IMPORTANT SAFETY INSTRUCTIONS

When using your telephone equipment, basic safety precautions should always be followed to reduce the risk of fire, electric shock and injury, including the following:

1. This product should be installed by a qualified technician.
2. This product should only be connected to the host equipment and never directly to the network such as Public Switch Telephone Network (PSTN) or Plain Old Telephone Services (POTS).
3. Read and understand all instructions.
4. Follow all warnings and instructions marked on the product.
5. Unplug this product from the wall outlet before cleaning. Do not use liquid or aerosol cleaners. Use a damp cloth for cleaning.
6. Do not use this product near water such as near a bath tub, wash bowl, kitchen sink, laundry tub or swimming pool, or in a wet basement or shower.
7. Do not place this product on an unstable table, shelf, stand or other unstable surfaces.
8. Slots and openings in the back or bottom of the telephone base and handset are provided for ventilation. To protect them from overheating, these openings must not be blocked by placing the product on a soft surface such as a bed, sofa or rug. This product should never be placed near or over a radiator or heat register. This product should not be placed in any area where proper ventilation is not provided.
9. This product should be operated only from the type of power source indicated on the marking label. If you are not sure of the type of power supply on the premises, consult your dealer or local power company.
10. Do not allow anything to rest on the power cord. Do not install this product where the cord may be walked on.
11. Never push objects of any kind into this product through the slots in the telephone base or handset because they may touch dangerous voltage points or create a short circuit. Never spill liquid of any kind on the product.
12. To reduce the risk of electric shock, do not disassemble this product, but take it to an authorized service facility. Opening or removing parts of the telephone base or handset other than specified access doors may expose you to dangerous voltages or other risks. Incorrect reassembling can cause electric shock when the product is subsequently used.
13. Do not overload wall outlets and extension cords.
14. Unplug this product from the wall outlet and refer servicing to an authorized service facility under the following conditions:
 - When the power supply cord or plug is damaged or frayed.
 - If liquid has been spilled onto the product.
 - If the product has been exposed to rain or water.
 - If the product does not operate normally by following the operating instructions. Adjust only those controls that are covered by the operation instructions. Improper adjustment of other controls may result in damage and often requires extensive work by an authorized technician to restore the product to normal operation.

- If the product has been dropped and the telephone base and/or handset has been damaged.
- If the product exhibits a distinct change in performance.

15. Avoid using a telephone (other than cordless) during an electrical storm. There is a remote risk of electric shock from lightning.

16. Do not use the telephone to report a gas leak in the vicinity of the leak. Under certain circumstances, a spark may be created when the adapter is plugged into the power outlet, or when the handset is replaced in its cradle. This is a common event associated with the closing of any electrical circuit. The user should not plug the phone into a power outlet, and should not put a charged handset into the cradle, if the phone is located in an environment containing concentrations of flammable or flame-supporting gases, unless there is adequate ventilation. A spark in such an environment could create a fire or explosion. Such environments might include: medical use of oxygen without adequate ventilation; industrial gases (cleaning solvents; gasoline vapors; etc.); a leak of natural gas; etc.

17. Only put the handset of your telephone next to your ear when it is in normal talk mode.

18. The power adapters are intended to be correctly oriented in a vertical or floor mount position. The prongs are not designed to hold the plug in place if it is plugged into a ceiling, under-the-table or cabinet outlet.

19. Use only the power cord and batteries indicated in this manual. Do not dispose of batteries in a fire. They may explode. Check with local codes for possible special disposal instructions.

20. In wall mounting position, make sure to mount the telephone base on the wall by aligning the eyelets with the mounting studs of the wall plate. Then slide the telephone base down on both mounting studs until it locks into place. Refer to the full instructions in Installation in the user's manual.

CAUTIONS

- Keep small metallic objects such as pins and staples away from the handset receiver.
- There may be a risk of explosion if a wrong type of handset battery is used (CTM-A2415, CTM-A2415HC). Use only the supplied rechargeable battery (BT164392/BT264392) or replacement battery (BT264392). Dispose of used batteries according to the information in The RBRC® seal in this user guide.

SAVE THESE INSTRUCTIONS

TABLE OF CONTENTS

Important safety instructions	2	Energy-saving charging mode	34
Parts check list	5	Maintenance	34
Telephone layout		Disclaimer and Limitation of Liability	35
Cordless 1-line CTM-A2415 Base	6	Technical specifications	
Cordless 1-line CTM-A2415 and CTM-A2415HC Handset	7	Cordless 1-line - CTM-A2415	36
Cordless 1-line CTM-A2415HC Charging Stand	8	Cordless Accessory Handset & Charging Stand - CTM-A2415HC	36
Installation			
Cordless 1-line - CTM-A2415	8		
Connection			
Cordless 1-line - CTM-A2415	11		
Cordless Accessory Handset & Charging stand - CTM-A2415HC	12		
Set up			
Cordless 1-line - CTM-A2415	13		
Cordless Accessory Handset & Charging stand - CTM-A2415HC	13		
Operation			
Cordless 1-line - CTM-A2415	16		
Cordless Accessory Handset & Charging stand - CTM-A2415HC	16		
Appendix			
CTM-A2415 Base battery	18		
CTM-A2415HC Handset battery	18		
Troubleshooting	20		
VTech Hospitality Limited Warranty Program	27		
FCC, ACTA and IC regulations	28		
Precautions for users of implanted cardiac pacemakers	32		
Operating range	32		
About cordless telephones	32		
The RBRC® seal	33		

Parts check list

Items contained in the respective **cordless telephone** package:

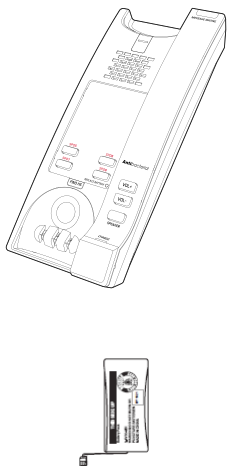
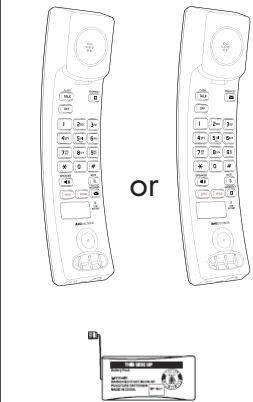
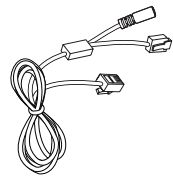
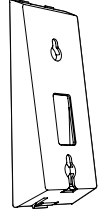
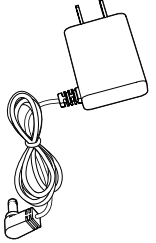
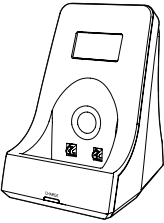
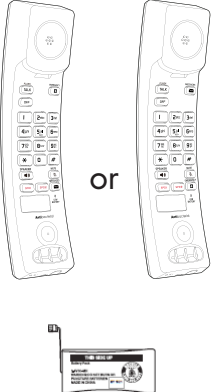
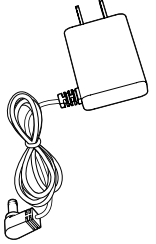
MODEL NAME	MODEL NUMBER	PARTS INCLUDED				
		TELEPHONE BASE WITH FACEPLATE AND OVERLAY CHARGING BASE	CORDLESS HANDSET AND HANDSET BATTERY	TELEPHONE LINE CORD WITH POWER CONNECTOR	BASE STAND WALL MOUNT BRACKET	POWER ADAPTER
Cordless 1-line	CTM-A2415					
Cordless 1-line accessory handset & charging base	CTM-A2415HC			--	--	

Telephone layout

Cordless 1-line CTM-A2415 Base

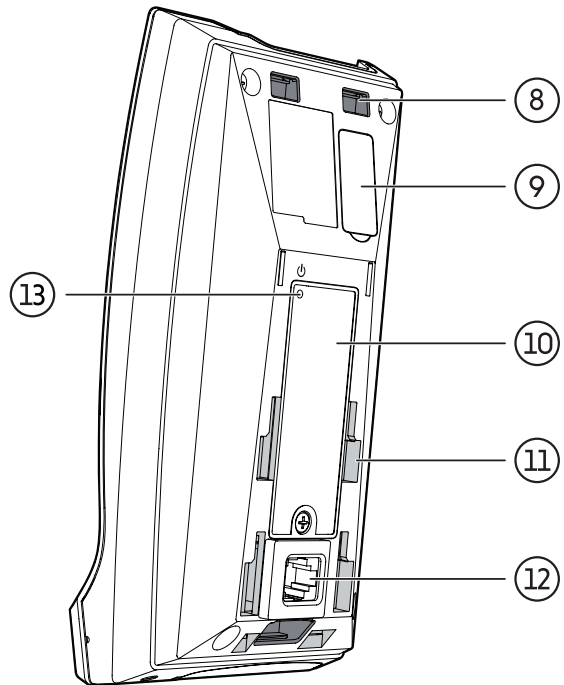
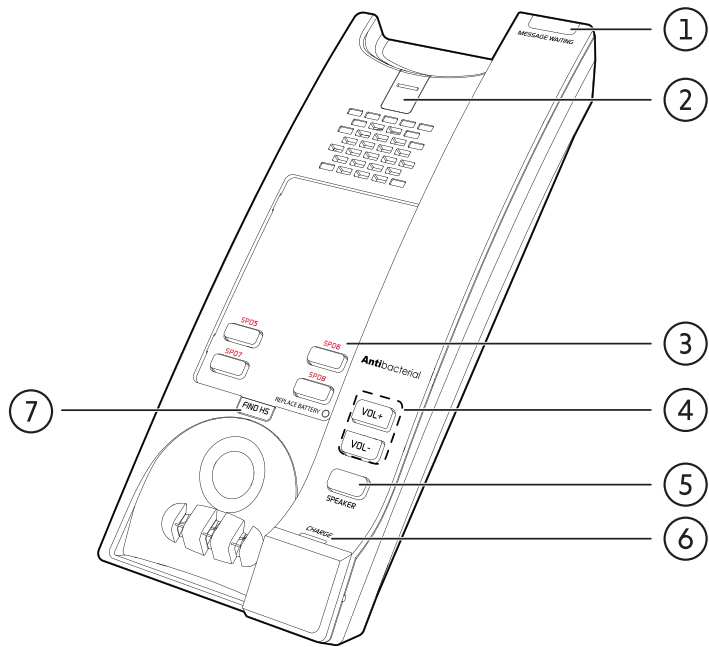

1	MESSAGE WAITING LED
2	Wall mount clip
3	Faceplate slot with Speed dial keys (Programmable)
	SPD5
	SPD6
	SPD7
	SPD8
	REPLACE BATTERY LED
4	VOL + VOL - (VOLUME +/-)
5	SPEAKER
6	CHARGE LED
7	FIND HS (FIND HANDSET)
8	Grooves for Mounting bracket
9	Voicemail voltage detection
10	Battery compartment with cover
11	Grooves for Base stand
12	Telephone jack
13	Base battery ON pinhole

Cordless 1-line CTM-A2415 and CTM-A2415HC Handset

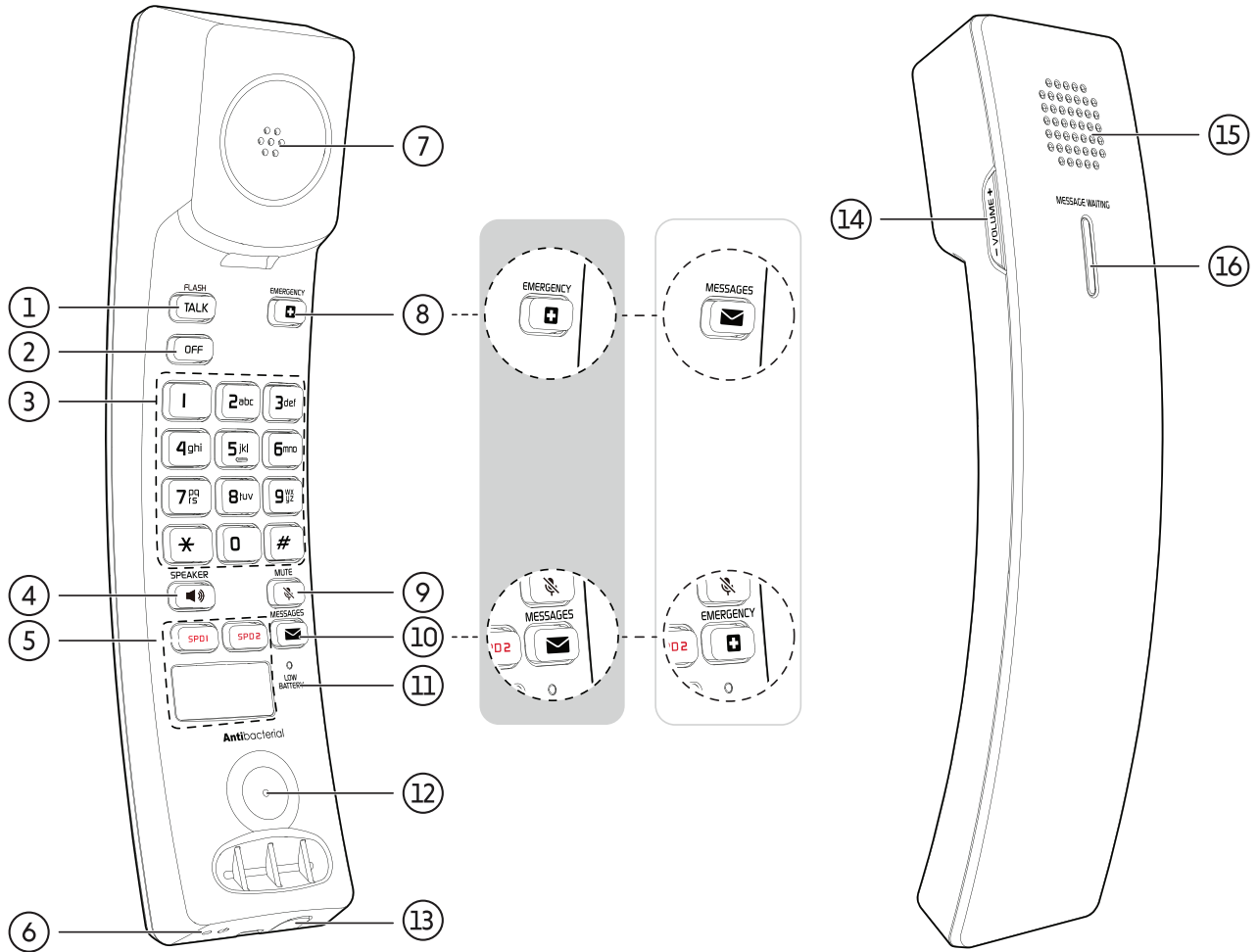

1	TALK FLASH
2	OFF
3	Numeric dial keys
4	SPEAKER
5	Speed Dial keys (Programmable)
	SPD1
	SPD2
6	Handset battery ON pinhole
7	Handset earpiece
*8	EMERGENCY (Programmable)
	MESSAGES (Programmable)
9	MUTE
*10	MESSAGES (Programmable)
	EMERGENCY (Programmable)
11	LOW BATTERY LED
12	Microphone
13	Handset screw cover
14	-/VOLUME/+

15	Speakerphone
16	MESSAGE WAITING LED

*Design is subject to change without prior notice.

Cordless 1-line CTM-A2415HC Charging Stand

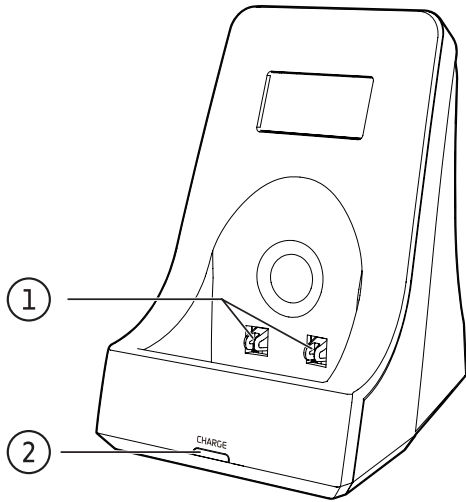

1	Charging poles
2	CHARGE LED

Installation

Cordless 1-line - CTM-A2415

INSTALLATION OPTION - INSTALL BASE STAND FOR DESKTOP

TO MOUNT THE BASE STAND

1. Align the grooves with the base stand.
2. Slide down to secure the stand.

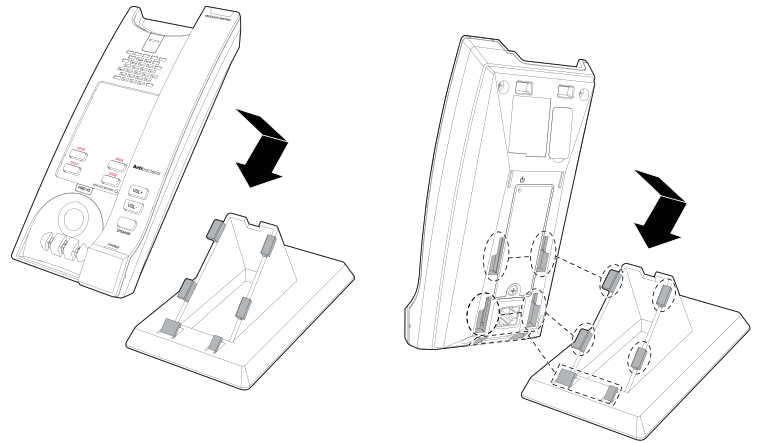

TO UNMOUNT THE BASE STAND

Simply slide up and lift the telephone base from the base stand.

INSTALLATION OPTION - CONVERTING FROM DESKTOP TO WALL MOUNT POSITION TO MOUNT THE TELEPHONE BASE ON THE WALL

1. Unmount the base stand. Put the cordless handset aside. On the telephone base, press the wall mount clip upward and rotate a half turn (180°). Slide back the clip.

- It locks into place with the protruding edge pointing towards the upper edge of the telephone base. This protruding edge holds the cordless handset when the phone is mounted on the wall.

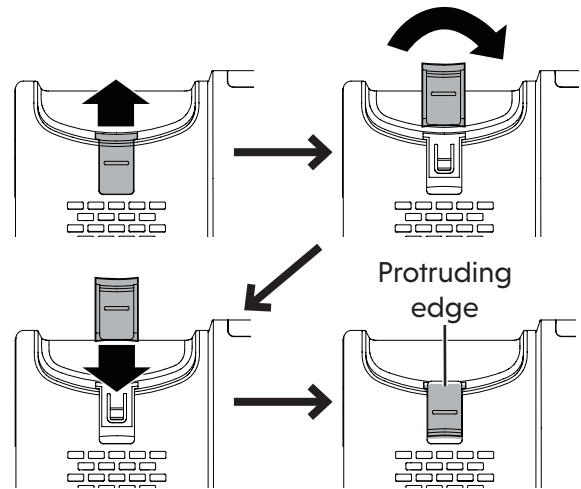

2. Turn the telephone base over with the bottom side facing up. Press the tabs of the mounting bracket as the direction indicated into the grooves on the telephone base until they lock securely.

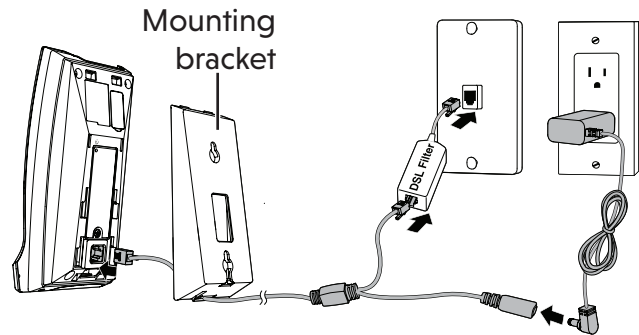

3. Mount the telephone base on the wall by positioning the eyelets on the telephone base and the mounting bracket against the mounting studs. Then slide the telephone base down on both mounting studs until it locks into place.

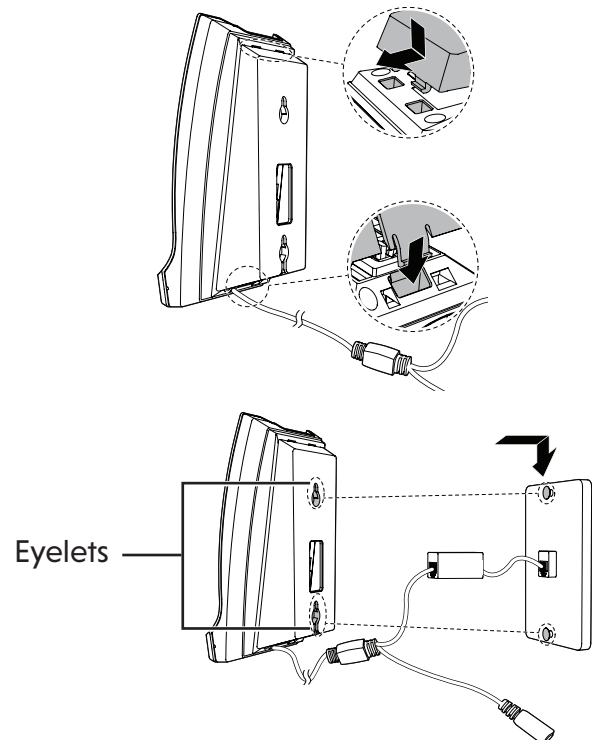

4. Replace the handset on the telephone base cradle.

REPLACE TELEPHONE BASE BATTERY INSTALLATION

The telephone base battery is pre-installed. To replace the telephone base battery, follow as shown below.

1. Remove the screw with cross head screwdriver. Gently open the battery compartment cover.

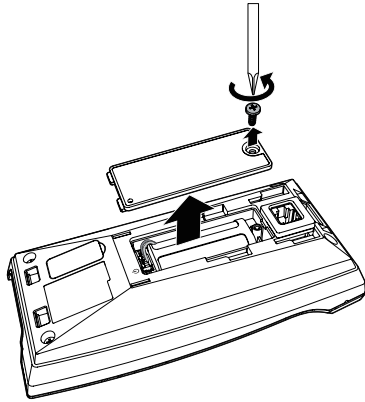

2. Remove the used battery from the compartment. Plug the new battery connector securely into the socket inside the base battery compartment. Place the battery with the label **THIS SIDE UP** facing up and the wires inside the battery compartment.

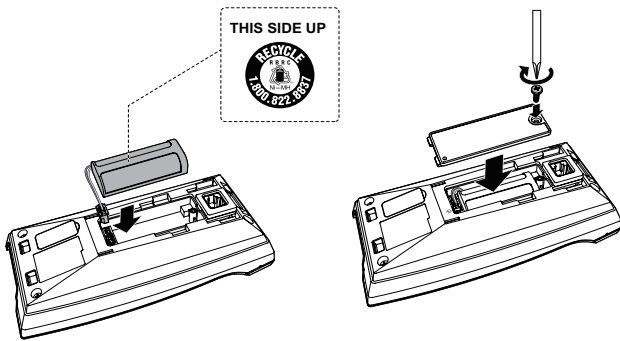

3. To replace the handset cover, align all the tabs on the base compartment battery cover against the corresponding grooves, then install the screw.

REPLACE A HANDSET BATTERY INSTALLATION

The handset battery is pre-installed. To replace the handset battery, follow as shown below.

1. Use a narrow object to pry open the screw cover and remove the screw with cross head screwdriver. Then, insert a 5 mm standard flat head screwdriver in the provided slot and gently open the handset cover.

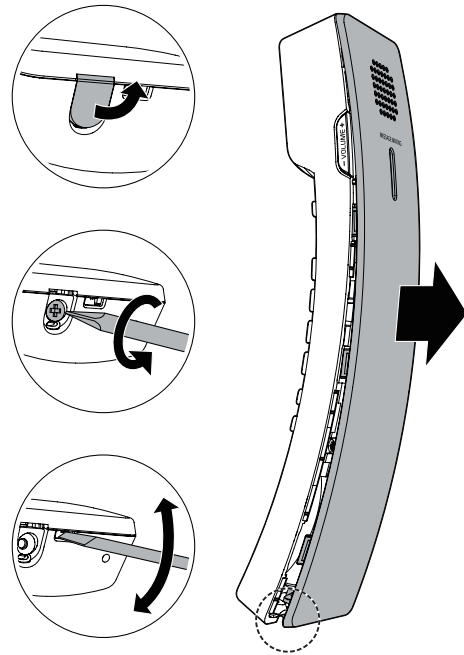

2. Unplug the battery connector from the socket and then remove the battery from the handset battery compartment.

3. Plug the battery connector securely into the socket inside the handset battery compartment. Place the battery with the label **THIS SIDE UP** facing up and the wires inside the battery compartment.

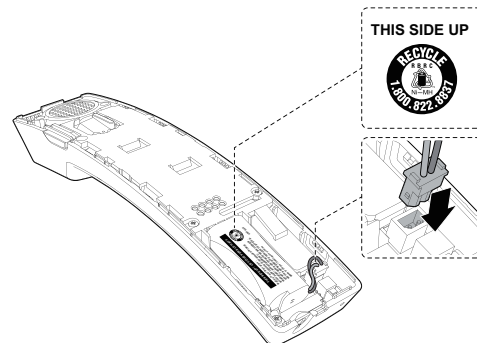

- To replace the handset cover, align all the tabs on the handset cover against the corresponding grooves on the handset, then firmly push downward until all the tabs lock in the grooves. Then install the screw.

⚠ CAUTIONS

- There may be a risk of explosion if a wrong type of handset battery is used. Use only the supplied rechargeable battery (BT164392/BT264392) or replacement battery (BT264392). To order a replacement, call 1-888-907-2007.
- FCC ID is shown on the back of the cordless handset body after the handset cover is removed.
- Dispose of used batteries according to the information in The RBRC® seal.

Connection

Cordless 1-line - CTM-A2415

TELEPHONE BASE INSTALLATION

The telephone comes ready for desktop use.

- Install the telephone base as shown below.

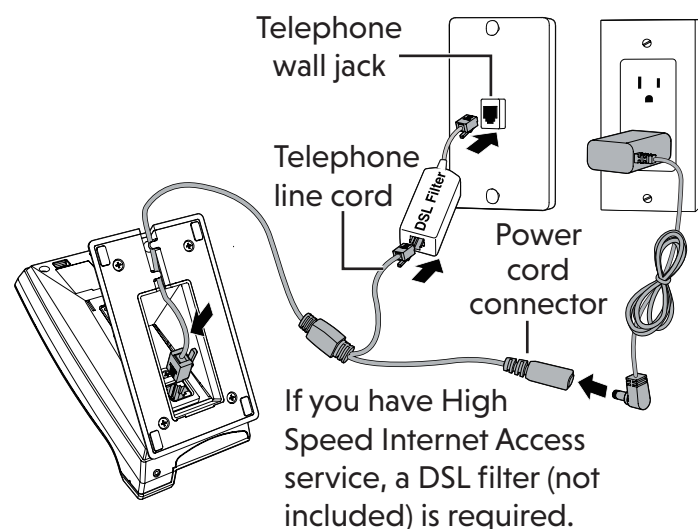

- When the telephone base has been initially installed, make sure the power adapter is securely plugged into an outlet not controlled

by a wall switch, and the telephone line cord is plugged firmly into the power adapter and the telephone wall jack.

- Bend a small paperclip and gently insert it to the Base battery ON pinhole and Handset battery ON pinhole to turn on the base and the handset.

- Without turning on the battery, the base and the handset cannot be charged.
 - Charge the base to enable battery backup feature.
 - The battery is fully charged after 12 hours of continuous charging. For best performance, keep the cordless handset in the telephone base when not in use.
- Press **SPEAKER** on the telephone base. Listen for a dial tone, and then press **SPEAKER** again to hang up.

⚠ CAUTION

Use only the supplied cable and power adapter. The supplied cable is not designed for use in any other IT devices. Misuse it on your other IT devices shall be prohibited. To order a replacement, call 1-888-907-2007.

Cordless Accessory Handset & Charging stand - CTM-A2415HC

CHARGER BASE INSTALLATION

The telephone comes ready for desktop use.

1. Install the charger base as shown below.
 - Make sure the power adapter is securely plugged into an outlet not controlled by a wall switch.

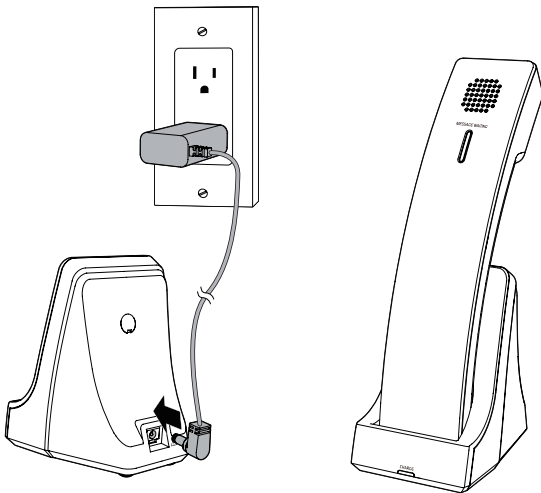

2. Bend a small paperclip and gently insert it to the Handset battery ON pinhole to turn on the handset.

- Without turning on the battery, the handset cannot be charged.
- The battery is fully charged after 12 hours of continuous charging. For best performance, keep the cordless handset in the charging base when not in use.

3. Press **[SPEAKER]** on the handset. Listen for a dial tone, and then press **[SPEAKER]** again to hang up.

⚠ CAUTION

Use only the supplied power adapter. The supplied power adapter is not designed for use in any other IT devices. Misuse it on your other IT devices shall be prohibited. To order a replacement, call 1-888-907-2007.

HANDSET REGISTRATION

Place the cordless handset on the telephone base cradle. Handset registration happens automatically the first time a cordless handset is placed on the telephone base.

When the registration process completes, the **MESSAGE WAITING** LED flashes once and you hear 3 rising beeps as confirmation.

Each telephone base accommodates up to 4 cordless handsets. When you already have 4 registered handsets, you can replace one of them by a new handset if any one of the 4 registered handsets is disconnected from the base. For example, it is out of range, or its battery is removed or depleted. The previous registered handset is then deregistered from the telephone base.

HANDSET DEREGISTRATION

When a registered cordless handset is idle, press ***331734#**. You hear a confirmation tone when the deregistration process completes.

REGISTER A HANDSET TO ANOTHER TELEPHONE BASE

When a registered cordless handset is idle, place it on another telephone base. This cordless handset automatically registers to the new telephone base.

HANDSET BATTERY CHARGING

The batteries must be fully charged before using the cordless base and the handset for the first time. The **CHARGE** LED turns on when the cordless handset is charging on the telephone base or charging base. The battery is fully charged after 12 hours of continuous charging. For best performance, keep the cordless handset in the telephone base or charging base when not in use.

Set up

Cordless 1-line - CTM-A2415

Cordless Accessory Handset & Charging stand - CTM-A2415HC

PROGRAM PHONE SETTINGS

In order to program different telephone settings, you have to enter **ADMIN** mode during system idle by pressing ***7764#MUTE** on the handset. You will hear 3 rising beeps as confirmation.

- During **ADMIN** mode, **MUTE** key LED on handset, the **MESSAGE WAITING** LED and **SPEAKER** LED on the base will blink.

To quit **ADMIN** mode with your settings, press **OFF** key, and you will hear 2 rising beeps to confirm. To quit **ADMIN** mode without saving your settings, press **OFF** key before entering the setting value.

PHONE SETTINGS

Default settings are indicated by asterisks (*).

Some settings have their corresponding **Access Keys** or **Access Codes**. After entering the setting value, you will hear a confirmation tone, and the **ADMIN** mode will quit.

SETTING	ACCESS CODE/ KEY	OPTIONS	ADJUSTABLE BY
Listening volume- Handset		1, 2, 3, 4*, 5, 6	User and administrator
Speakerphone volume - Handset		1, 2, 3, 4*, 5, 6	User and administrator
Speakerphone volume - telephone base		1, 2, 3, 4*, 5, 6	User and administrator
Ringer volume - telephone base		1, 2*, 3	User and administrator
Ringer tone	00	Tone 1*, Tone 2, Tone 3	Administrator only
Flash	FLASH	1 (100ms), 2 (300ms), 3* (600ms)	Administrator only
RF transmission power - telephone base	01	1 (low), 2* (middle), 3 (high)	Administrator only
Voicemail voltage detection <ul style="list-style-type: none"> • Steady high voltage, periodic high voltage pulse and periodic low voltage pulse detection method • Line reversal method • FSK detection method • Panasonic 	<ul style="list-style-type: none"> • 10 • 11 (Line rev.) • 12 (FSK) • 14 (Panasonic) 	0 (disable), 1 (enable)	Administrator only
Voicemail voltage detection <ul style="list-style-type: none"> • Siemens 	13	0 (disable), 1 (50Hz), 2 (25Hz), 3 (20Hz)	Administrator only

RINGER TONE

There are 3 ringer tone options that can be assigned to the telephone base.

TO CHANGE THE RINGER TONE

1. Press ***7764#MUTE** on the handset to enter **ADMIN** mode.
2. Press **00**. Then press a dialing key **1**, **2** or **3** to select the desired ringer tone. You hear 3 rising beeps as confirmation.

FLASH

There are 3 flash duration options that can be programmed.

TO CHANGE THE FLASH DURATION

1. Press ***7764#MUTE** on the handset to enter **ADMIN** mode.
2. Press **FLASH**. Then, press a dialing key, **1** (100ms), **2** (300ms) or **3** (600ms), to select the desired flash duration. You hear 3 rising beeps as confirmation.

RF TRANSMISSION POWER

There are 3 RF transmission power options on the telephone base that can be programmed.

TO CHANGE THE RF TRANSMISSION POWER CONTROL LEVEL

1. Press ***7764#MUTE** on the handset to enter **ADMIN** mode.
2. Press **01**. Then, press a dialing key
 - **1** (low - coverage of 25% of maximum working distance),
 - **2** (middle - coverage of 50% maximum working distance) or
 - **3** (high - coverage of 100% of maximum working distance),

to select the desired RF transmission power control level. You hear 3 rising beeps as confirmation.

VOICEMAIL VOLTAGE DETECTION

There are several voicemail voltage detection methods on the telephone base that can be programmed.

TO CHANGE THE VOICEMAIL VOLTAGE DETECTION BY THE STEADY HIGH VOLTAGE, PERIODIC HIGH VOLTAGE PULSE AND PERIODIC LOW VOLTAGE PULSE DETECTION METHOD

1. Press ***7764#MUTE** on the handset to enter **ADMIN** mode.
2. Press **10**. Then, press a dialing key, **0** (disable) or **1** (enable), to select the desired setting. You hear 3 rising beeps as confirmation.

TO CHANGE THE VOICEMAIL VOLTAGE DETECTION BY THE LINE REVERSAL METHOD

1. Press ***7764#MUTE** on the handset to enter **ADMIN** mode.
2. Press **11**. Then press a dialing key, **0** (disable) or **1** (enable), to select the desired setting. You hear 3 rising beeps as confirmation.

TO CHANGE THE VOICEMAIL VOLTAGE DETECTION BY THE FSK DETECTION METHOD

1. Press ***7764#MUTE** on the handset to enter **ADMIN** mode.
2. Press **12**. Then, press a dialing key, **0** (disable) or **1** (enable), to select the desired setting. You hear 3 rising beeps as confirmation.

TO CHANGE THE VOICEMAIL VOLTAGE DETECTION BY THE PANASONIC DETECTION METHOD

1. Press ***7764#MUTE** on the handset to enter **ADMIN** mode.
2. Press **14**. Then, press a dialing key, **0** (disable) or **1** (enable), to select the desired setting. You hear 3 rising beeps as confirmation.





TO CHANGE THE VOICEMAIL VOLTAGE DETECTION BY THE SIEMENS DETECTION METHOD

1. Press ***7764#MUTE** on the handset to enter **ADMIN** mode.
2. Press **13**. Then, press a dialing key, **0** (disable), **1** (50Hz), **2** (25Hz), or **3** (20Hz), to select the desired setting. You hear 3 rising beeps as confirmation.





SPEED DIAL KEYS

This telephone has up to 8 programmable guest-service (Speed Dial) keys. Program these keys to automatically dial telephone numbers or to activate telephone system features.

EXAMPLES FOR CTM-A2415

Speed dial key	Faceplate with Speed dial key	Speed dial value (default)
SPD5	FRONT DESK 	24106
SPD6	ROOM SERVICE 	24107
SPD7	MESSAGE 	24111
SPD8	EMERGENCY 	24105

EXAMPLES FOR CTM-A2415HC

Speed Dial keys	Sticker for Speed dial key	Speed dial value (default)
SPD1	FRONT DESK 	24106
SPD2	ROOM SERVICE 	24107
	EMERGENCY 	24105
	MESSAGES 	24111

TO PROGRAM A SPEED DIAL KEY

1. Press ***234636#MUTE** on the handset to enter **SPEED DIAL PROGRAMMING** mode. You hear 3 beeps while **MUTE** key (on handset) and all LEDs (on base) are flashing.
2. Press the desired Speed Dial key where the telephone number is to be stored.
3. Enter the telephone number (up to 32 digits). Press the same Speed Dial key to confirm. You hear 3 rising beeps as confirmation.
 - To insert a pause in the stored number, press the **SPEAKER** key on the handset.
 - The telephone can store maximum 32 digits.
4. To program other Speed Dial keys, repeat steps 2 and 3.
5. Press **OFF** key to quit **SPEED DIAL PROGRAMMING** mode.

TO CLEAR THE PROGRAMMED SPEED DIAL KEY

1. Press ***234636#MUTE** on the handset to enter **SPEED DIAL PROGRAMMING** mode.
2. Press the Speed Dial key twice where the telephone number is to be deleted. You hear 3 rising beeps as confirmation.

Operation

Cordless 1-line - CTM-A2415

Cordless Accessory Handset & Charging stand - CTM-A2415HC

USING THE CORDLESS HANDSET AND THE TELEPHONE BASE

The cordless handset and the telephone base cannot be used on the same call. However, calls can be switched between the cordless handset and the telephone base speakerphone.

When the cordless handset or the telephone base is in use, the **TALK** key on the cordless handset or the **SPEAKER** LED on the telephone base illuminate.

RECEIVE A CALL

The telephone rings when there is an incoming call. The **MESSAGE WAITING** LEDs flash.

ANSWER A CALL USING THE CORDLESS HANDSET WHILE IT IS NOT ON THE TELEPHONE BASE OR CHARGING BASE

On the cordless handset, press **TALK** or **SPEAKER**.

- The **TALK** key illuminates when in use. The **SPEAKER** key illuminates when in speakerphone mode.

ANSWER A CALL USING THE CORDLESS HANDSET WHILE IT IS CRADLED ON THE TELEPHONE BASE OR CHARGING BASE

Lift the cordless handset from the telephone base or charging base.

- The **TALK** key illuminates when in use. The **SPEAKER** key illuminates when in speakerphone mode.

ANSWER A CALL USING THE TELEPHONE BASE

On the telephone base, press **SPEAKER**.

- The **SPEAKER** key illuminates when in use.

PLACE A CALL

PLACE A CALL USING THE CORDLESS HANDSET

On the cordless handset, press **TALK** or **SPEAKER**. Listen for a dial tone and then dial the desired number, or press a Speed Dial key on the telephone base to dial a programmed number.

- The **TALK** key illuminates when in use. The **SPEAKER** key illuminates when in speakerphone mode.

PLACE A CALL USING THE TELEPHONE BASE

On the telephone base, press **SPEAKER**. Listen for a dial tone and then press a Speed Dial key on the telephone base to dial a programmed number.

- The **SPEAKER** key illuminates when in use.

END A CALL

END A CALL WHEN USING THE CORDLESS HANDSET

Press **OFF** on the cordless handset or place it in the telephone base or charging base. The call ends when all handsets hang up.

END A CALL WHEN USING THE TELEPHONE BASE

Press **SPEAKER**.

SWITCH A CALL BETWEEN THE CORDLESS HANDSET AND THE TELEPHONE BASE SPEAKERPHONE

- To switch a call from the cordless handset to the telephone base speakerphone, press **SPEAKER** on the telephone base.

- To switch a call from the telephone base speakerphone to the cordless handset which is not on the telephone base cradle, press **TALK** or **⏸**/ **SPEAKER** on the cordless handset.
- To switch a call from the telephone base speakerphone to the cordless handset which is cradled on the telephone base, lift the cordless handset from the telephone base.

SHARE A CALL

A maximum of four cordless handsets can be used at the same time on an external call.

JOIN A CALL

During a call, press **TALK** or **⏸**/ **SPEAKER** on another cordless handset to join.

HANDSET SPEAKERPHONE

During a call, press **⏸**/ **SPEAKER** on the cordless handset to switch between speakerphone mode and handset earpiece mode.

VOLUME

Listening volume can be adjusted on the cordless handset and the telephone base.

ADJUST THE LISTENING VOLUME

- During a call on the handset, press **-VOLUME+** on it to adjust the listening volume. The next call returns to the default listening volume.
- During a call on the telephone base, press **VOL+** and **VOL-** to adjust the listening volume. The next call returns to the default listening volume.

ADJUST THE RINGER VOLUME OF THE TELEPHONE BASE

Ringer volume of the telephone base can be adjusted. When the telephone base is idle, press **VOL+** and **VOL-** to adjust the ringer volume.

CALL WAITING

1. When you hear a call waiting tone during a call, press **TALK** on the cordless handset or the telephone base to put the current call on hold and take the new incoming call.
2. Press **TALK** at any time to switch back and forth between calls.

MUTE

MUTE THE MICROPHONE

1. During a call, press **MUTE** on the cordless handset or the telephone base.
 - The **MUTE** key illuminates when the mute function is turned on. You can hear the party on the other end but they cannot hear you.
2. Press **MUTE** again to resume the conversation.
 - The light on the **MUTE** key turns off.

FIND HANDSET

Use this feature to find all registered cordless handsets.

START PAGING

Press **FIND HS** (FIND HANDSET) on the telephone base when the telephone is not in use. All idle cordless handsets beep for 60 seconds.

END PAGING

- Press **FIND HS** (FIND HANDSET) again on the telephone base; or
- Press any key on the cordless handset to stop the paging tone.

Appendix

CTM-A2415 Base backup battery

It takes up to 12 hours for the battery to be fully charged. When the base experiences a power cut, you can expect the following performance:

OPERATION	OPERATING TIME
While in handset use (talking*)	Up to 90 minutes
While in speakerphone mode on the telephone base (talking*)	Up to 30 minutes
While not in use (standby**)	Up to 90 minutes

* Operating times vary depending on your actual use and the age of the battery.

** Base is not charging or in use.

The battery needs charging when:

- A new battery is installed in the base.

The battery needs replacement when:

- **REPLACE BATTERY** LED illuminates on the base.

CTM-A2415HC Handset battery

It takes up to 12 hours for the battery to be fully charged. When it is fully charged, you can expect the following performance:

OPERATION	OPERATING TIME
While in handset use (talking*)	Up to 7 hours
While in speakerphone mode (talking*)	Up to 5 hours
While not in use (standby**)	Up to 7 days

* Operating times vary depending on your actual use and the age of the battery.

** Handset is not charging or in use.

The battery needs charging when:

- A new battery is installed in the handset.
- **LOW BATTERY** LED illuminates on the cordless handset.

⚠ CAUTIONS

To reduce the risk of fire or injury, read and follow these instructions:

- Use only the supplied rechargeable battery (BT164392/BT264392) or replacement battery (BT264392). To order a replacement, contact your local distributor.
- Do not dispose of the battery in a fire. Check with local waste management codes for special disposal instructions.
- Do not open or mutilate the battery. Released electrolyte is corrosive and may cause burns or injury to the eyes or skin. The electrolyte may be toxic if swallowed.
- Exercise care in handling the battery in order not to create a short circuit with conductive materials.
- Charge the battery provided with or identified for use with this product only in accordance with the instructions and limitations specified in this user guide.
- Observe proper polarity orientation between the battery and metallic contacts.
- To prevent fire or shock hazard, do not expose this product to water or any type of moisture.

Appendix

Troubleshooting

If you have difficulty with the telephones, please try the suggestions below. For customer service, visit our website at www.vtechhotelphones.com or call 1-888-907-2007.

FOR CORDLESS TELEPHONE

QUESTION	SUGGESTIONS
The telephone does not work at all.	<ul style="list-style-type: none">• Make sure the power adapter is securely plugged into an outlet not controlled by a wall switch.• Make sure the telephone line cord is plugged firmly into the power adapter and the telephone wall jack.• Make sure the battery is installed and charged correctly (page 10-12). For optimum daily performance, return the cordless handset to the telephone base or charging base after use.• Unplug the electrical power to the telephone base. Wait for approximately 15 seconds, then plug it back in. Allow up to one minute for the cordless handset and the telephone base to synchronize.• Charge the battery in the cordless handset for up to 12 hours.• If the battery is completely depleted, charge the cordless handset for at least 30 minutes before use.• Remove the battery and then install it again. If that still does not work, it may be necessary to purchase a new battery.• Disconnect the telephone base from the telephone wall jack and plug in a working telephone. If the other telephone does not work, the problem is probably in the wiring or telephone service. Contact your telephone service provider (charges may apply).

QUESTION

SUGGESTIONS

There is no dial tone.

- Try all the above suggestions.
- Make sure there is a dial tone before dialing. It is normal if the cordless handset takes a second or two to synchronize with the telephone base before producing a dial tone. Wait an extra second before dialing.
- Eliminate any background noise. Mute the telephone before dialing, if applicable, or dial from another room in your unit with less background noise.
- If other telephones in your hotel are having the same problem, the problem is in the wiring or telephone service. Contact your telephone service provider (charges may apply).

I cannot dial out.

- Try all the above suggestions.
- Make sure there is a dial tone before dialing.
- Eliminate any background noise. Mute the telephone before dialing, if applicable, or dial from another room in your unit with less background noise.
- If other telephones in your hotel are having the same problem, the problem is in the wiring or telephone service. Contact your telephone service provider (charges may apply).

The **LOW BATTERY** LED illuminates on the cordless handset.

- Place the cordless handset in the telephone base or charging base for recharging.
- Remove the battery and then install it again, and use it until fully depleted. Then charge the cordless handset in the telephone base or charging base for up to 12 hours.
- If the above measures do not correct the problem, replace the battery.

QUESTION**SUGGESTIONS**

The battery does not charge in the cordless handset or the battery does not accept charge.

- Make sure the cordless handset is placed in the telephone base or charging base correctly. The **CHARGE** LED should be on.
- Remove the battery and then install it again. Charge it for up to 12 hours.
- If the cordless handset is in the telephone base or charging base but the **CHARGE** LED is not on, refer to **The CHARGE LED is off** below.
- If the battery is completely depleted, charge the cordless handset for at least 30 minutes before use.
- If the above measures do not correct the problem, replace the battery.

The **CHARGE** LED is off.

- Clean the charging contacts on the cordless handset, telephone base and charging base each month with a pencil eraser or a dry non-abrasive fabric.
- Make sure the power adapter and telephone line cord are plugged in correctly and securely.
- Unplug the power adapter. Wait for 15 seconds before plugging it back in. Allow up to one minute for the cordless handset and the telephone base to reset.

The telephone does not ring when there is an incoming call.

- Make sure the telephone line cord and the power adapter are plugged in properly (page 11-12).
- The cordless handset may be too far from the telephone base. Move it closer to the telephone base.
- Adjust the setting of RF transmission power (page 14). It may be out of range.
- If other telephones in your hotel are having the same problem, the problem is in the wiring or telephone service. Contact your telephone service provider (charges may apply).
- Other electronic products such as HAM radios and other DECT phones can cause interference with the cordless phone. Try installing the phone as far away as possible from these types of electronic devices.
- Test a working telephone at the telephone wall jack. If the other telephone has the same problem, the problem is in the telephone wall jack. Contact your telephone service provider (charges may apply).
- The telephone line cord may be defective. Install a new telephone line cord.
- Remove the battery and then install it again. Then place the cordless handset in the telephone base. Wait for the handset to synchronize with the telephone base. Allow up to one minute for this to take place.

QUESTION

The cordless handset beeps and is not performing normally.

SUGGESTIONS

- Make sure the power cord is securely plugged into the telephone base. Plug the telephone base into a different working electrical outlet not controlled by a wall switch.
 - Move the cordless handset closer to the telephone base or adjust the setting of RF transmission power (page 14). It may be out of range.
 - Reset the telephone base by unplugging the electrical power to the base. Wait for 15 seconds and plug it back in again. Allow up to one minute for the cordless handset and the telephone base to synchronize.
 - Other electronic products such as HAM radios and other DECT phones can cause interference with the cordless phone. Try installing the phone as far away as possible from these types of electronic devices.
-

There is interference during a telephone conversation, or the call fades in and out when I am using the cordless handset.

- Move the handset closer to the telephone base or adjust the setting of RF transmission power (page 14). It may be out of range.
- If there is High Speed Internet Access (HSIA) available at the premises through a telephone line, you may need to install a DSL filter (DSL - digital subscriber line) between the telephone line cord and the telephone wall jack. The filter prevents noise and caller ID problems caused by DSL interference. Contact your DSL service provider for more information about DSL filters.
- Appliances or other cordless telephones plugged into the same circuit as the telephone base can cause interference. Try moving the appliance or the telephone base to another outlet.
- Other electronic products such as HAM radios and other DECT phones can cause interference with the cordless phone. Try installing the phone as far away as possible from these types of electronic devices.
- If the telephone is plugged in with a modem or a surge protector, plug the telephone (or modem/surge protector) into a different location. If this doesn't solve the problem, relocate the telephone or modem farther apart from each other, or use a different surge protector.
- The location of the telephone base can impact the performance of the cordless phone. For better reception, install the telephone base in a centralized location within the room, away from walls or other obstructions.
- Disconnect the telephone base from the telephone wall jack and plug in a corded telephone. If calls are still not clear, the problem is probably in the wiring or telephone service. Contact your telephone service provider (charges may apply).

QUESTION	SUGGESTIONS
There is interference during a telephone conversation, or the call fades in and out when I am using the cordless handset.	<ul style="list-style-type: none"> • If other telephones in your hotel are having the same problem, the problem is in the wiring or telephone service. Contact your telephone service provider (charges may apply).
I hear other calls when using the telephone.	<ul style="list-style-type: none"> • Disconnect the telephone base from the telephone wall jack. Plug in a different telephone. If you still hear other calls, the problem is probably in the wiring or telephone service. Contact your telephone service provider (charges may apply).
I hear noise on the cordless handset and the keys do not work.	<ul style="list-style-type: none"> • Make sure the telephone line cord is plugged in securely.
Reset instructions for common issues.	<ul style="list-style-type: none"> • If the telephone is not responding normally, put the cordless handset in the telephone base. If it does not fix the problem, try the following (in the order listed): <ol style="list-style-type: none"> 1. Disconnect the power to the telephone base. 2. Disconnect the battery on the cordless handset. 3. Wait a few minutes before connecting power to the telephone base. 4. Install the battery again and then place the cordless handset in the telephone base. 5. Wait for the cordless handset to synchronize with the telephone base. Allow up to one minute for this to take place.

Appendix

VTech Hospitality Limited Warranty Program

VTech Communications, Inc., the manufacturer of VTech Hospitality Product ("Product"), warrants to the holder of a valid proof of purchase ("end user" or "you") that the Product and all accessories provided by VTech in the Product's package are free from defects in material and workmanship, pursuant to the following terms and conditions, when installed and used normally and in accordance with the Product's operating instructions. The limited warranty extends to the end user of this Product and applies only if such Product is purchased through a United States of America and/or Canadian distributor. The limited warranty period for this Product is determined based on the following:

5 YEARS – ANALOG MODELS

- All Classic Models – corded and cordless
- All Contemporary Models – corded and cordless
- All TrimStyle Models

2 YEARS – SIP NON-DISPLAY MODELS

- All Classic Models – corded and cordless
- All Contemporary Models – corded and cordless
- All TrimStyle Models

During the limited warranty period, VTech's authorized service representative will replace, at VTech's option, without charge, a Product that is not free from defects in materials and workmanship. If the Product is replaced, it may be replaced with a new or refurbished Product of the same or similar design. Replacement of Product, at VTech's option, is the exclusive remedy.

The limited warranty period for the Product begins on the date that the end user takes possession of the Product. This limited warranty also applies to replacement Products for a period of either: (a) 90 days from the date the replacement Product is shipped to you; or (b) the time remaining on the original limited warranty as described above; whichever is longer.

This limited warranty does not cover:

1. Product or parts that have been subjected to misuse, accident, shipping or other physical damage, improper installation, abnormal operation or handling, neglect, inundation, fire, water or other liquid intrusion; or
2. Product that has been damaged due to repair, alteration or modification by anyone other than an authorized service representative of VTech; or
3. Product to the extent that the problem experienced is caused by signal conditions, network reliability or cable or antenna systems; or
4. Product to the extent that the problem is caused by use with non-VTech accessories; or
5. Product whose warranty/quality stickers, product serial number plates or electronic serial

numbers have been removed, altered or rendered illegible; or

6. Product purchased, used, serviced, or shipped for repair from outside the United States or Canada, or used for non-approved commercial or institutional purposes (including but not limited to Products used for rental purposes); or
7. Product returned without valid proof of purchase; or
8. Charges or costs incurred by the end user, and risk of loss or damage, in removing and shipping the Product, or for installation or set up, adjustment of customer controls, and installation or repair of systems outside the unit.
9. Line cords or coil cords, plastic overlays, connectors, power adapters and batteries, if the Product is returned without them. VTech will charge the end user at then-current prices for each of the missing items.
10. NiCd or NiMH handset batteries, or power adapters, which, under all circumstances, are covered by a one (1) year warranty only.

Except as provided by applicable law, you assume the risk of loss or damage during transit and transportation and are responsible for delivery or handling charges incurred in the transport of Product(s) to the service location. VTech's authorized service representative will return replaced product under this limited warranty to you, transportation, delivery and handling charges prepaid. VTech assumes no risk for damage or loss of the Product in transit.

OTHER LIMITATIONS

This warranty is the complete and exclusive agreement between you and VTech. It supersedes all other written or oral communications related to this Product. VTech provides no other warranties for this Product, whether express or implied, oral or written, or statutory. The warranty exclusively describes all of VTech's responsibilities regarding the Product. No one is authorized to make modifications to this warranty and you should not rely on any such modification.

VTech's liability to end user hereunder shall not exceed the purchase price of the Product. In no event shall VTech be liable for any indirect, special, incidental, consequential, or similar damages (including, but not limited to lost profits or revenue, inability to use the product, or other associated equipment, the cost of substitute equipment, and claims by third parties) resulting from the use of this Product. Some states/provinces do not allow the exclusion or limitation of incidental or consequential damages, so the above limitation or exclusion may not apply to you.

This warranty gives you specific legal rights, and you also have other rights which vary from state to state or province to province.

Appendix

FCC, ACTA and IC regulations

FCC PART 15

This equipment has been tested and found to comply with the requirements for a Class B digital device under Part 15 of the Federal Communications Commission (FCC) rules. These requirements are intended to provide reasonable protection against harmful interference in a residential

installation. This equipment generates, uses and can radiate radio frequency energy and, if not installed and used in accordance with the instructions, may cause harmful interference to radio communications. However, there is no guarantee that interference will not occur in a particular installation. If this equipment does cause harmful interference to radio or television reception, which can be determined by turning the equipment off and on, the user is encouraged to try to correct the interference by one or more of the following measures:

- Reorient or relocate the receiving antenna.
- Increase the separation between the equipment and receiver.
- Connect the equipment into an outlet on a circuit different from that to which the receiver is connected.
- Consult the dealer or an experienced radio/TV technician for help.

Changes or modifications to this equipment not expressly approved by the party responsible for compliance could void the user's authority to operate the equipment.

This device complies with Part 15 of the FCC rules. Operation is subject to the following two conditions: (1) this device may not cause harmful interference, and (2) this device must accept any interference received, including interference that may cause undesired operation.

This Class B digital apparatus complies with Canadian ICES-003.

FCC PART 68 AND ACTA

This equipment complies with Part 68 of the FCC rules and with technical requirements adopted by the Administrative Council for Terminal Attachments (ACTA). The label on the back or bottom of this equipment contains, among other things, a product identifier in the format US:AAAKXNANXXXX. This identifier must be provided to your telephone service provider upon request.

The plug and jack used to connect this equipment to premises wiring and the telephone network must comply with applicable Part 68 rules and technical requirements adopted by ACTA. A compliant telephone cord and modular plug is provided with this product. It is designed to be connected to a compatible modular jack that is also compliant. An RJ11 jack should normally be used for connecting to a single line. See the installation instructions in the user's manual.

The Ringer Equivalence Number (REN) is used to determine how many devices you may connect to your telephone line and still have them ring when you are called. The REN for this product is encoded as the 6th and 7th characters following the US: in the product identifier (e.g., if ## is 03, the REN is 0.3). In most, but not all areas, the sum of all RENs should be five (5.0) or less. For more information, please contact your telephone service provider.

This equipment may not be used with Party Lines. If you have specially wired alarm dialing equipment connected to your telephone line, ensure the connection of this equipment does not disable your alarm equipment. If you have questions about what will disable alarm equipment, consult your telephone service provider or a qualified installer.

If this equipment is malfunctioning, it must be unplugged from the modular jack until the problem has been corrected.

To ensure safety of users, the FCC has established criteria for the amount of radio frequency energy of the product. This product has been tested and found to comply with the FCC criteria. The handset may be safely held against the ear of the user. The telephone base shall be installed and used such that parts of the user's body other than the hands are maintained at a distance of approximately 20 cm (8 inches) or more.

If this equipment is causing harm to the telephone network, your telephone service

provider may temporarily discontinue your telephone service. Your telephone service provider is required to notify you before interrupting service. If advance notice is not practical, you will be notified as soon as possible. You will be given the opportunity to correct the problem and your telephone service provider is required to inform you of your right to file a complaint with the FCC. Your telephone service provider may make changes in its facilities, equipment, operation, or procedures that could affect the proper functioning of this product. Your telephone service provider is required to notify you if such changes are planned.

If this product is equipped with a corded or cordless handset, it is hearing aid compatible.

If this product has memory dialing locations, you may choose to store emergency telephone numbers (e.g., police, fire, medical) in these locations. If you do store or test emergency numbers, please:

Remain on the line and briefly explain the reason for the call before hanging up.

Perform such activities in off-peak hours, such as early morning or late evening.

When the adjunct is used with a leased system, permission of the owner of the equipment must be obtained for connection of the adjunct because modification of the host system is often required.

This product can only be connected to the host equipment and never directly to the network.

INDUSTRY CANADA

This product meets the applicable Innovation, Science and Economic Development Canada technical specifications.

The Ringer Equivalence Number (REN) is an indication of the maximum number of devices allowed to be connected to a telephone interface. The termination of an interface may

consist of any combination of devices subject only to the requirement that the sum of the RENs of all the devices not exceed five.

Le présent matériel est conforme aux spécifications techniques applicables d'Innovation, Sciences et Développement économique Canada.

L'indice d'équivalence de la sonnerie (IES) sert à indiquer le nombre maximal de terminaux qui peuvent être raccordés à une interface téléphonique. La terminaison d'une interface peut consister en une combinaison quelconque de dispositifs, à la seule condition que la somme d'indices d'équivalence de la sonnerie de tous les dispositifs n'excède pas cinq.

ISED WARNING

This device complies with Innovation, Science, and Economic Development Canada licence-exempt RSS standard(s). Operation is subject to the following two conditions:

1. This device may not cause interference, and
2. This device must accept any interference, including interference that may cause undesired operation of the device.

Privacy of communications may not be ensured when using this telephone.

The device is compliance with RF exposure guidelines, users can obtain Canadian information on RF exposure and compliance.

AVERTISSEMENT ISED

Cet appareil est compatible avec la licence de l'Innovation, la Science et le développement économique du Canada à l'exemption des normes RSS. Le fonctionnement est sujet aux deux (2) conditions suivantes :

- (1) Cet appareil peut ne pas causer de l'interférence, et
- (2) Cet appareil doit accepter l'interférence, incluant de l'interférence qui peut causer un mauvais fonctionnement de cet appareil.

La confidentialité des communications peut ne pas être garantie lors de l'utilisation de ce téléphone.

L'appareil est compatible avec les directives de l'exposition RF, les utilisateurs peuvent obtenir les renseignements pour le Canada sur l'exposition RF et sa conformité.

Appendix

Precautions for users of implanted cardiac pacemakers

Cardiac pacemakers (applies only to digital cordless telephones):

Wireless Technology Research, LLC (WTR), an independent research entity, led a multidisciplinary evaluation of the interference between portable wireless telephones and implanted cardiac pacemakers. Supported by the U.S. Food and Drug Administration, WTR recommends to physicians that:

Pacemaker patients

- Should keep wireless telephones at least six inches from the pacemaker.
- Should NOT place wireless telephones directly over the pacemaker, such as in a breast pocket, when it is turned ON.
- Should use the wireless telephone at the ear opposite the pacemaker.

WTR's evaluation did not identify any risk to bystanders with pacemakers from other persons using wireless telephones.

Operating range

The cordless telephone operates with the maximum power allowed by the Federal Communications Commission (FCC). Even so, the cordless handset and telephone base can communicate over only a certain distance - which can vary with the locations of the telephone base, cordless handset, the weather, and the layout of the hotel.

When the cordless handset is out of range while on a call, the cordless handset rapidly beeps three times.

If there is a call while the handset is out of range, it may not ring, or if it does ring, the call may not connect well when you answer the call. Move closer to the telephone base to answer the call.

If the handset moves out of range during a telephone conversation, there may be interference.

To improve reception, move closer to the telephone base.

About cordless telephones

Privacy: The same features that make a cordless telephone convenient create some limitations. Telephone calls are transmitted between the telephone base and the cordless handset by radio waves, so there is a possibility that the cordless telephone conversations could be intercepted by radio receiving equipment within range of the cordless handset. For this reason, you should not think of cordless telephone conversations as being as private as those on corded telephones.

Electrical power: The telephone base of the cordless telephone must be connected to a working electrical outlet. The electrical outlet should not be controlled by a wall switch. Calls cannot be made from the cordless handset if the telephone base is unplugged, switched off or if the electrical power is interrupted.

Potential TV interference: Some cordless telephones operate at frequencies that may cause interference to televisions and VCRs. To minimize or prevent such interference, do not place the telephone base of the cordless telephone near or on top of a TV or VCR. If interference is experienced, moving the cordless telephone farther away from the TV or VCR often reduces or eliminates the interference.

Rechargeable batteries: Exercise care in handling batteries in order not to create a short circuit with conducting material such as rings, bracelets and keys. The battery or conductor may overheat and cause harm. Observe proper polarity between the battery and the battery charger.

Nickel-metal hydride rechargeable batteries: Dispose of these batteries in a safe manner. Do

not burn or puncture the battery. Like other batteries of this type, if burned or punctured, they could release caustic material which could cause injury.

The RBRC® seal

The RBRC® seal on the nickel-metal hydride battery indicates that VTech Communications, Inc. is voluntarily participating in an industry program to collect and recycle these batteries at the end of their useful lives, when taken out of service within the United States and Canada.



The RBRC® program provides a convenient alternative to placing used nickel-metal hydride batteries into the trash or municipal waste, which may be illegal in your area.

VTech's participation in RBRC® makes it easy for you to drop off the spent battery at local retailers participating in the RBRC® program or at authorized VTech product service centers. Please call 1 (800) 8 BATTERY™ for information on Ni-MH battery recycling and disposal bans/restrictions in your area. VTech's involvement in this program is part of its commitment to protecting our environment and conserving natural resources.



RBRC® is a registered trademark of Rechargeable Battery Recycling Corporation.

Appendix

Energy-saving charging mode

When this mode is activated, all telephone functions, except handset battery charging, will be disabled.

TO ACTIVATE THE ENERGY-SAVING CHARGING MODE IN A2415/A2415HC:

1. Unplug the telephone base backup battery or press switch to shut down the backup battery. Unplug the power adapter from the power outlet. Unplug the telephone line cord from the telephone wall jack.
 - Make sure all handsets are plugged with charged batteries before proceeding.
2. While you press and hold  /**FIND HANDSET**, plug the telephone base power back to the power outlet.
3. After about 20 seconds, when the IN USE light starts flashing, release  /**FIND HANDSET** and then press it again within 2 seconds. When the telephone base successfully enters the energy-saving charging mode, all keys on the telephone base should not respond.
4. Press *331734# and then press **MUTE** to deregister each handset manually.

WHEN THE PHONE SUCCESSFULLY ENTERS THE ENERGY-SAVING MODE, THE **IN USE** LIGHT TURNS OFF AND YOU HEAR 3 RISING BEEPS.

WHEN THE PHONE FAILS TO ENTER THIS MODE, REPEAT STEP 1 THROUGH STEP 4 ABOVE.

NOTE

The telephone base will be powered up as normal if you fail to press  /**FIND HANDSET** within 2 seconds in Step 3.

TO DEACTIVATE THE ENERGY-SAVING CHARGING MODE:

Unplug the telephone base adapter from the power outlet. Then plug the telephone base power adapter and the telephone line cord back in. Then the telephone base is powered up as normal.

Register the handsets back to the telephone base. See page 12 for handset registration instructions.

Maintenance

TAKING CARE OF YOUR TELEPHONE

Your telephone contains sophisticated electronic parts, so it must be treated with care.

AVOID ROUGH TREATMENT

Place the handset down gently. Save the original packing materials to protect your telephone if you ever need to ship it.

AVOID WATER

Your telephone can be damaged if it gets wet. Do not use the handset outdoors in the rain, or handle it with wet hands. Do not install the telephone base near a sink, bathtub or shower.

ELECTRICAL STORMS

Electrical storms can sometimes cause power surges harmful to electronic equipment. For your own safety, take caution when using electrical appliances during storms.

CLEANING YOUR TELEPHONE

Your telephone has a durable plastic casing that should retain its luster for many years. Clean it only with a soft cloth slightly dampened with water or mild soap. Do not use excess water or cleaning solvents of any kind.

Disclaimer and Limitation of Liability

VTech Communications, Inc. and its suppliers assume no responsibility for any damage or loss resulting from the use of this user's manual. VTech Communications, Inc. and its suppliers assume no responsibility for any loss or claims by third parties that may arise through the use of this product. VTech Communications, Inc. and its suppliers assume no responsibility for any damage or loss caused by deletion of data as a result of malfunction or dead battery. Be sure to make backup copies of important data on other media to protect against data loss.

Company: VTech Communications, Inc.

Address: 9020 SW Washington Square Road.,
Suite 555, Tigard, OR 97223, United States

Phone: 1 (888) 907-2007

REMEMBER THAT ELECTRICAL APPLIANCES CAN CAUSE SERIOUS INJURY IF USED WHEN YOU ARE WET OR STANDING IN WATER. IF THE TELEPHONE BASE SHOULD FALL INTO WATER, DO NOT RETRIEVE IT UNTIL YOU UNPLUG THE POWER CORD AND/OR TELEPHONE LINE CORD FROM THE WALL. THEN REMOVE THE TELEPHONE BY THE UNPLUGGED CORDS.

Technical specifications

Cordless 1-line - CTM-A2415

Cordless Accessory Handset & Charging Stand - CTM-A2415HC

Frequency control	Crystal controlled PLL synthesizer
Transmit frequency	Handset: 1921.536-1928.448 MHz Telephone base: 1921.536-1928.448 MHz
Channels	5
Nominal effective range	Maximum power allowed by FCC and IC. Actual operating range may vary according to environmental conditions at the time of use.
Power requirement	Handset: 2.4V Ni-MH battery Telephone base backup battery: 2.4V Ni-MH battery Telephone base: 6V DC @400mA Charging stand: 6V DC @400mA
Message waiting signal	Steady/periodic high voltage pulse, periodic low voltage pulse, reverse polarity, FSK, Siemens and/or Panasonic
Speed Dial memory	Telephone base: up to 4 memory locations; up to 32 digits Handset: up to 4 memory locations; up to 32 digits
Size	Telephone base: 2.93 x 5.67 x 5.39 in (74.5 x 144 x 137 mm) Handset: 1.89 x 8.27 x 1.57 in (48 x 210 x 40 mm) Charging stand: 2.76 x 3.78 x 4.17 in (70 x 96 x 106 mm)



Specifications are subject to change without notice.

VTECH Telecommunications Inc.

All rights reserved. 12/20.

Near Terms Cordless_CTM2415-2415HC_CEC_US-CA_201215