

Go to www.vtechphones.com to register your product for enhanced warranty support and the latest VTech product news.

CS6719
CS6719-15
CS6719-16
CS6719-17
CS6719-2
CS6719-26
CS6719-27

DECT 6.0 cordless telephone



vtech

Abridged user's manual

Congratulations

on purchasing your new VTech product. Before using this product, please read **Important safety instructions**.

This abridged user's manual provides you with basic installation and use instructions. A limited set of features are described in abbreviated form.

Please refer to the online User's manual for a full set of installation and operation instructions at www.vtechphones.com.



Telephones identified with this logo have reduced noise and interference when used with most T-coil equipped hearing aids and cochlear implants. The TIA-1083 Compliant Logo is a trademark of the Telecommunications Industry Association. Used under license.

What's in the box

Your product package contains the following items. Save your sales receipt and original packaging in the event warranty service is necessary.

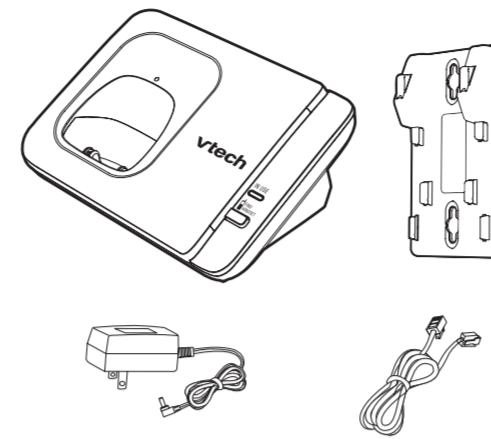

1 set for CS6719/
CS6719-15/
CS6719-16/
CS6719-17;
2 sets for CS6719-2/
CS6719-26
CS6719-27

1 set for CS6719-2/
CS6719-26
CS6719-27

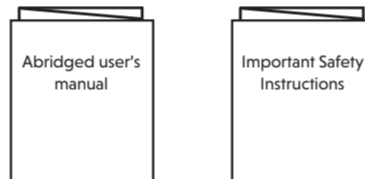

Handset overview

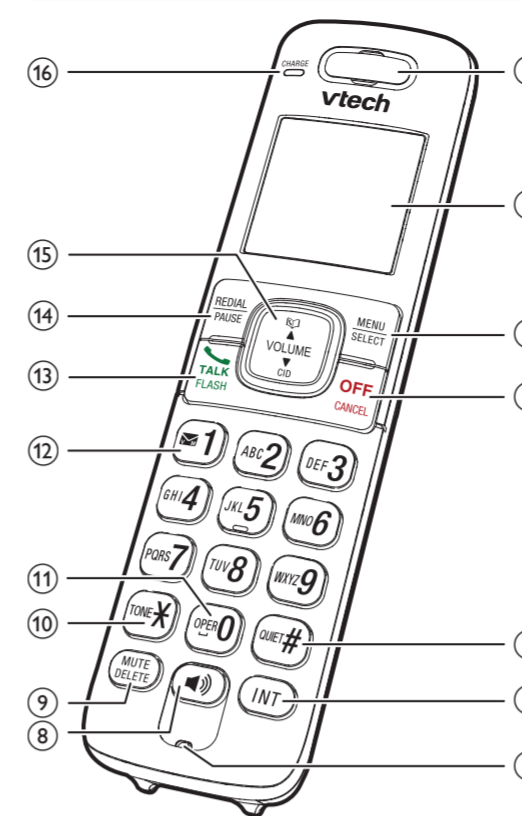

- 1 - Handset earpiece**
- 2 - LCD display**
- 3 - MENU/SELECT**
 - Show the menu.
 - While in a menu, press to select an item, or save an entry or setting.
- 4 - OFF/CANCEL**
 - Hang up a call.
 - Silence the ringer temporarily while the handset is ringing.
 - Press and hold to erase the missed call indicator while the phone is not in use.
 - Press to return to the previous menu; or press and hold to return to idle mode, without making changes.
- 5 - QUIET #**
 - Press repeatedly to show other dialing options when reviewing a caller ID log entry.
- 6 - INT**
 - Press to start an intercom conversation or transfer a call (for multi-handset models only).

7 - Microphone

- 8 - MUTE**
 - Make or answer a call using the handset speakerphone.
 - During a call, press to switch between the speakerphone and the handset.

9 - MUTE/DELETE

- Mute the microphone during a call.
- Delete digits or characters while using the dialing keys.
- Silence the ringer temporarily while the handset is ringing.

10 - TONE X

- While you have set the dial mode to pulse and on a call, press to switch to tone dialing temporarily.

11 - OPER 0

- Press to add a space when entering names.

12 - 1

- Press repeatedly to add or remove 1 in front of the caller ID log entry before dialing or saving it to the directory.
- Press and hold to set or dial your voicemail number.

13 - TALK /FLASH

- Make or answer a home call.
- Answer an incoming home call when you hear a call waiting alert.

14 - REDIAL/PAUSE

- Press repeatedly to review the redial list.
- Press and hold to insert a dialing pause while entering a number.

15 - VOLUME/▲/▼

- Review the directory when the phone is not in use.
- Increase the listening volume during a call.
- Scroll up while in a menu, or in the directory, caller ID log, or redial list.
- Move the cursor to the right when entering numbers or names.

VOLUME/▼/CID

- Review the caller ID log when the phone is not in use.
- Decrease the listening volume during a call.
- Scroll down while in a menu, or in the directory, caller ID log, or redial list.
- Move the cursor to the left when entering numbers or names.

16 - CHARGE light

- On when the handset is charging.

Telephone base overview

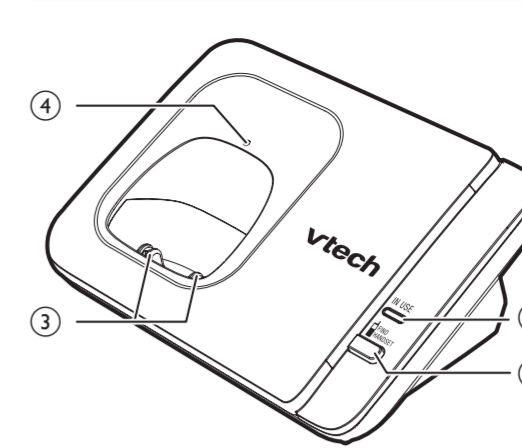

1 - IN USE light

- Flashes when there is an incoming call, or another telephone sharing the same line is in use.
- On when the handset is in use.

2 - FIND HANDSET

- Press to page all system handsets.

3 - Charging pole

4 - Charge light

Charger overview

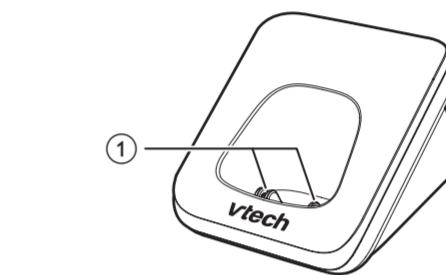

1 - Charging pole

Display icons overview

	The battery icon flashes when the battery is low and needs charging.
	The battery icon animates when the battery is charging.
	The battery icon becomes solid when the battery is fully charged.
	The handset ringer is off.
	There are new voicemail received from your telephone service provider.
	The ECO mode activates automatically to reduce power consumption when the handset is within range from the telephone base.
	There are new caller ID log entries.

Connect

You can choose to connect the telephone base for desktop usage or wall mounting.

- NOTE: Use only the power adapters supplied with this product.

- TIP: If you subscribe to digital subscriber line (DSL) high-speed Internet service through your telephone line, make sure you install a **DSL filter** (not included) between the telephone line cord and telephone wall jack. Contact your DSL service provider for more information.

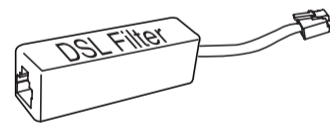

Connect the telephone base

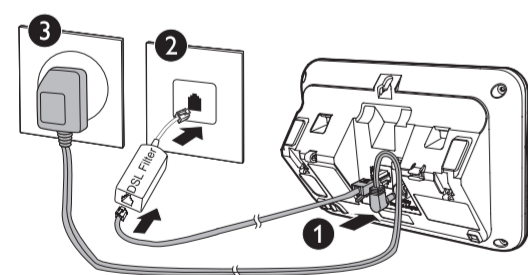

Connect the charger

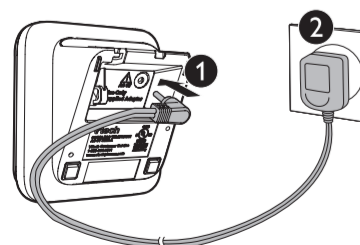

Mount the telephone base

The telephone comes ready for tabletop use. If you have already installed the telephone for tabletop use, unplug the telephone line cord from the telephone wall jack, and unplug the telephone base power adapter from the wall outlet before mounting your telephone on a wall. Follow the steps below to mount your telephone on a wall.

- Route the telephone line cord through the rectangular hole on the wall mount bracket. Then plug the two ends of the telephone line cord into the telephone base and the wall outlet as shown.

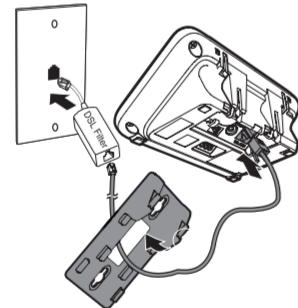

- Align the holes on the bracket with the standard wall plate and slide the bracket down until it clicks securely in place.

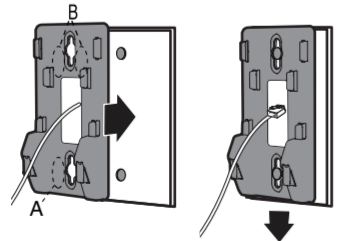

- Align the grooves on the telephone base with the tabs on the wall mount bracket, and then slide it down until it clicks securely in place.

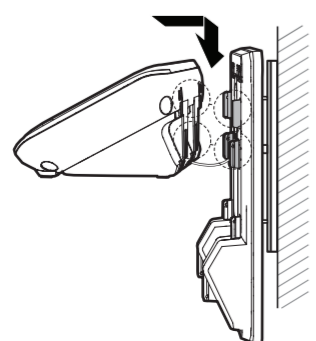

- Connect the power adapter to the telephone base and an electrical outlet not controlled by a wall switch.

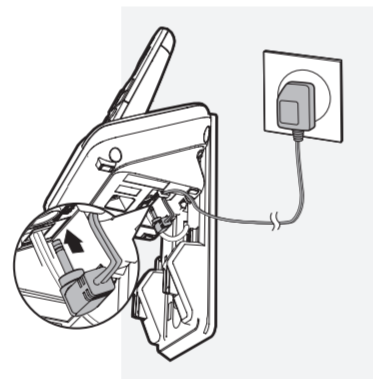

Install and charge the battery

Install the battery

Install the battery as shown below.

- NOTE: Use only supplied battery.
- If the handset will not be used for a long time, disconnect and remove the battery to prevent possible leakage.

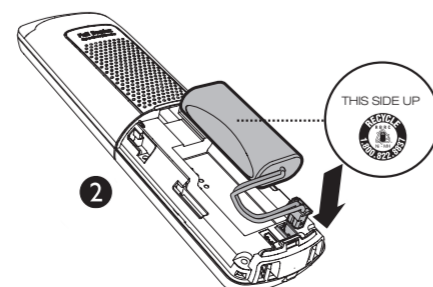
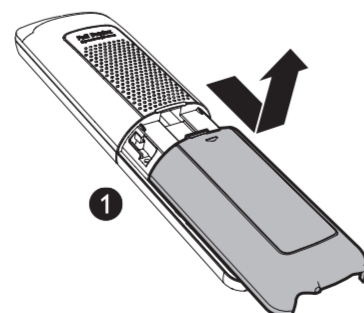

Charge the battery

Place the handset in the telephone base or the charger to charge.



Once you have installed the battery, the handset LCD display indicates the battery status (see the table below).

- NOTE: For best performance, keep the handset in the telephone base or charger when not in use.
- The battery is fully charged after 12 hours of continuous charging.

Battery indicators	Battery status	Action
The screen is blank, or shows no charge or very little charge. The handset cannot be used.	The battery has no charge or very little charge. The handset cannot be used.	Charge without interruption (at least 30 minutes).
The screen shows Low battery and flashes.	The battery has enough charge to be used for a short time.	Charge without interruption (at least 30 minutes).
The screen shows HANDSET X .	The battery is charged.	To keep the battery charged, place it in the telephone base or charger when not in use.

Before use

After you install your telephone or power returns following a power outage, the handset or telephone will prompt you to set the date and time.

Set date and time

- Use the dialing keys (0-9) to enter the month (MM), date (DD) and year (YY). Then press **SELECT**.
- Use the dialing keys (0-9) to enter the hour (HH) and minute (MM). Then press **▼** or **▲** to choose **AM** or **PM**.
- Press **SELECT** to save.

Check for dial tone:

Press **TALK**. If you hear a dial tone, the installation is successful.

If you do not hear a dial tone:

- Make sure the installation procedures described above are properly done.
- It may be a wiring problem. If you have changed your telephone service to digital service from a cable company or a VoIP service provider, the telephone line may need to be rewired to allow all existing telephone jacks to work. Contact your cable/VoIP service provider for more information.

Operating range

This cordless telephone operates with the maximum power allowed by the Federal Communications Commission (FCC). Even so, this handset and telephone base can communicate over only a certain distance - which can vary with the locations of the telephone base and handset, the weather, and the layout of your home or office.

When the handset is out of range, the handset displays **Out of range** or **no pwr** at base.

If there is a call while the handset is out of range, it may not ring, or if it does ring, the call may not connect well when you press **TALK**. Move closer to the telephone base, and then press **TALK** to answer the call. If the handset moves out of range during a telephone conversation, there may be interference. To improve reception, move closer to the telephone base.

Using the handset menu

- Press **MENU** when the phone is not in use.
- Press **▼** or **▲** until the screen displays the desired feature menu.
- Press **SELECT** to enter that menu.
- To return to the previous menu, press **CANCEL**.
- To return to idle mode, press and hold **CANCEL**.

Configure your telephone

Set language

The LCD language is preset to English. You can select English, French or Spanish to be used in all screen displays.

- Press **MENU** when the handset is not in use.
- Scroll to **Settings**, and then press **SELECT** twice.
- Scroll to choose **English**, **Français** or **Español**, and then press **SELECT**.
- Press **SELECT** again to save.

Set date and time

- Press **MENU** when the handset is not in use.
- Scroll to **Set date/time**, and then press **SELECT**.
- Use the dialing keys (0-9) to enter the month (MM), date (DD) and year (YY). Then press **SELECT**.
- Use the dialing keys (0-9) to enter the hour (HH) and minute (MM). Then press **▼** or **▲** to choose **AM** or **PM**.
- Press **SELECT** to save.

Temporary tone dialing

If you have pulse (rotary) service only, you can switch from pulse to tone dialing temporarily during a call.

- During a call, press **TONE X**.
- Use the dialing keys to enter the relevant number. The telephone sends touch-tone signals. It automatically returns to pulse dialing mode after you end the call.

Telephone operation

Handset control key panel:

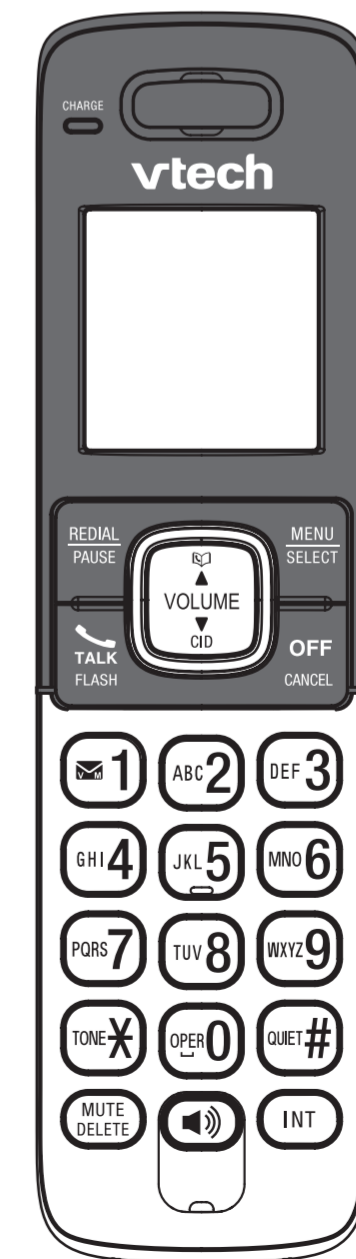

Make a call

- Press **TALK** or **MUTE**, and then dial the telephone number.

Answer a call

- Press **TALK**, **MUTE**, or any dialing key.

End a call

- Press **OFF** on the handset, or put the handset to the base or charger.

Speakerphone

- During a call, press **MUTE** on the handset to switch between speakerphone and normal handset use.

Volume

- During a call, press **▼/VOLUME/▲** on the handset to adjust the listening volume.

NOTE

The handset earpiece volume setting and speakerphone volume setting are independent.

Mute

The mute function allows you to hear the other party but the other party cannot hear you.

- During a call, press **MUTE** on the handset or telephone base. The screen displays **Muted**.
- Press **MUTE** again to resume the conversation. The screen displays **Microphone ON**.

Call waiting

When you subscribe to call waiting service from your telephone service provider, you hear an alert tone if there is an incoming call while you are on another call.

- Press **FLASH** to put the current call on hold and take the new call.
- Press **FLASH** to switch back and forth between calls.

Find handset

Use this feature to find all system handsets.

- To start paging: Press **FIND HANDSET** on the telephone base. All idle handsets ring and display **** Paging ****.

To end paging:

- Press **FIND HANDSET** again on the telephone base.

-OR-

- Press **TALK**, **MUTE**, **OFF**, or any dialing key on the handset.

-OR-



- Place the handset in the telephone base or charger.

NOTE

- Do not **press and hold** / **FIND HANDSET** for more than four seconds. It may lead to handset deregistration.



Join a call in progress

You can use up to two system handsets at a time on a home line call. You can buy additional expansion handsets (**CS6709**) for this telephone base. You can register up to five handsets to the telephone base.

- When a handset is on a home call, press  or  on another handset to join the call.
- Press **OFF** to exit the call. The call continues until all handsets hang up.



Transfer a call

While on an outside call, you can transfer the call from one handset to another.

- Press **MENU** on your handset during a call.
- Scroll to **Transfer**, and then press **SELECT**.
- Use the dialing keys to enter a destination handset number.
- To answer the intercom call, press , , or any dialing key on the destination handset.

Intercom



Use the intercom features for conversations between two devices.

- Press **INT** on your handset when not in use.
- Use the dialing keys to enter a destination handset number.
- To answer the intercom call, press , , or any dialing key on the destination handset.
- To end the intercom call, press **OFF** or place the handset back in the telephone base or charger.

Transfer a call using intercom

While on an outside call, you can use the intercom feature to transfer the call from one handset to another.

- The current call is put on hold.
- Use the dialing keys to enter a destination handset number.

- To answer the intercom call, press , , or any dialing key on the destination handset. You can now have a private conversation before transferring the call.

- From this intercom call, you have the following options:

- You can let the destination handset join you on the outside call in a three-way conversation. **Press and hold INT** on the originating handset.
- You can transfer the call. Press **OFF**, or place your handset back in the telephone base or charger. Your handset displays **Transferred**. The destination handset is then connected to the outside call.
- You can press **INT** to switch between the outside call (**Outside call** displays) and the intercom call (**Intercom** displays).
- The destination handset can end the intercom call by pressing **OFF**, or by placing the handset back in the telephone base or charger. The outside call continues with the original system handset.

Answer an incoming call during an intercom call

If you receive an incoming call during an intercom call, there is an alert tone.

- To answer a call, press . The intercom call ends automatically.
- To end the intercom call without answering the outside call, press **OFF**. The intercom call ends and the telephone continues to ring.

Redial list

Each handset stores the last 10 telephone numbers dialed. When there are already 10 entries, the oldest entry is deleted to make room for the new entry.

Review the redial list

- Press **REDIAL** when the handset is not in use.
- Press **▼**, **▲**, or **REDIAL** repeatedly until the desired entry displays.

Dial a redial list entry

- Press  or  to dial.

Delete a redial list entry

When the desired redial entry displays, press **DELETE**.

Directory

The phonebook can store up to 50 entries, which are shared by all handsets. Each entry may consist of a telephone number up to 30 digits, and a name up to 15 characters.

Add a directory entry



- Press **MENU** when the phone is not in use.
- Scroll to **Directory** then press **SELECT**.
- Press **SELECT** again to choose **Add contact**.
- Enter the number.
 - Use the dialing keys to enter the number (up to 30 digits).
- Press **SELECT** to move to the name.
- Use the dialing keys to enter the name (up to 15 characters). Additional key presses show other characters of that particular key.
- Press **SELECT** to save.

While entering numbers and names, you can:



- Press **DELETE** to erase a digit or character.
- Press and hold DELETE** to erase the entire entry.
- Press **▼** or **▲** to move the cursor to the left or right.
- Press and hold PAUSE** to insert a dialing pause (for entering phone numbers only).
- Press **0** to add a space (for entering names only).
- Press ^{TOE}**X** to add **X** († appears) or ^{ONE}**#** to add **#** (‡ appears) (for entering phone numbers only).

Review the directory

Entries are sorted alphabetically.

- Press  when the phone is not in use.
- Scroll to browse through the directory, or use the dialing keys to start a name search (you can enter up to 3 characters for the search).
- When the desired entry appears, press , or  to dial.

Dial a directory entry

- When the desired entry appears, press , or  to dial.

Edit a directory entry

- When the desired entry displays, press **SELECT**.
- Use the dialing keys to edit the number, and then press **SELECT**.
- Use the dialing keys to edit the name, and then press **SELECT** to save.

Delete a directory entry:

- When the desired entry displays, press **DELETE**.
- When the screen displays **Delete contact?**, press **SELECT**.

Speed dial

You can copy up to 9 directory entries into the speed dial locations (**0** and **2-9**) so that you can dial these numbers using fewer keys than usual.

The speed dial memory locations are stored in the telephone base and are shared by all handsets. Changes made to the speed dial entries on one handset apply to all.

Assign a speed dial entry

- Press **MENU** when the phone is not in use.
- Scroll to **Directory**, then press **SELECT**.
- Scroll to **Speed dial**, then press **SELECT**.
- Press **▼** or **▲** or the dialing keys (**0** or **2-9**) to choose the desired speed dial location.
- Press **SELECT**. The screen displays **Copy from DIR...** and then the first entry in the directory.
- Scroll to browse to the desired entry.
 - OR-** Use the alphabetical search to find the desired entry.
- Press **SELECT** to save. You hear a confirmation. The name (up to 12 characters) appears in the selected speed dial location.

NOTES

- If the directory is empty, when you press **SELECT** in Step 5, the screen displays **Directory empty**.
- If the speed dial location you selected is occupied, the new directory entry you selected replaces the old one. Take caution not to replace entries you do not wish to delete from the speed dial locations.

Reassign a speed dial entry

- Press **MENU** when the phone is not in use.
- Scroll to **Directory**, then press **SELECT**.
- Scroll to **Speed dial**, then press **SELECT**.
- Press **▼** or **▲**, or use the dialing keys to choose the speed dial location you want to reassign.
- Press **SELECT** twice. The screen displays **Reassign SD**.
- Press **SELECT**. The screen displays **Copy from DIR...** and then the first entry of the directory.
- Scroll to browse to the desired entry.

-OR-

Use the alphabetical search to find the desired entry.

- Press **SELECT** to save. You hear a confirmation. The name (up to 12 characters) appears in the selected speed dial location.

Dial a speed dial number

- Press and hold** a dialing key (**0** or **2-9**) to dial the number stored in the corresponding speed dial location.

When the speed dial location is empty, the screen displays the speed dial list. See **Assign a speed dial entry** to add a new entry.

Delete a speed dial entry

- Press **MENU** when the phone is not in use.
- Scroll to **Directory**, then press **SELECT**.
- Scroll to **Speed dial**, then press **SELECT**.
- Press **▼** or **▲**, or use the dialing keys to choose the desired speed dial location, then press **DELETE**. The screen displays **Clear SD #X?**
- Press **SELECT** to confirm. You hear a confirmation tone.

NOTE

- Deleting the speed dial entries does not affect the entries in the directory.

Caller ID



If you subscribe to caller ID service, information about each caller appears after the first or second ring. If you answer a call before the caller information appears on the screen, it will not be saved in the caller ID log.

The caller ID log stores up to 50 entries. Each entry has up to 24 digits for the phone number and 15 characters for the name.

If the telephone number has more than 15 digits, only the last 15 digits appear. If the name has more than 15 characters, only the first 15 characters are shown and saved in the caller ID log.

Review a caller ID log entry

- Press **CID** when the phone is not in use.
- Scroll to browse through the caller ID log. When the desired entry appears:
 - Press **#** repeatedly to show different dialing options.

- Press **1** repeatedly if you need to add or remove 1 in front of the phone number.
- Press  or  to dial the displayed number.

Dial a caller ID log entry

- When the desired entry appears, press , or  to dial.

Save a caller ID log entry to the directory

- When the desired caller ID log entry displays, press **SELECT**.
- Scroll to **To Directory** then press **SELECT**.
- Use the dialing keys to modify the number, and then press **SELECT**.
- Use the dialing keys to modify the name, and then press **SELECT** to save.

Delete a caller ID log entry

- When the desired caller ID log entry displays, press **DELETE**.

Delete all caller ID log entries

- Press **MENU** when the phone is not in use. Scroll to **Caller ID log** and then press **SELECT**. Scroll to **Del all calls** and then press **SELECT** twice.

Sound settings

Key tone

You can choose from different ringer tones.

- Press **MENU** when the handset is not in use.
- Scroll to **Settings**, and then press **SELECT**.
- Scroll to choose **Key tone**, and then press **SELECT**.
- Scroll to choose **On** or **Off**, and then press **SELECT** to save.

Ringer tone

You can choose from different ringer tones.

- Press **MENU** when the handset is not in use.
- Scroll to **Ringers**, and then press **SELECT**.
- Scroll to choose **Ringer tone**, and then press **SELECT**.
- Scroll to sample each ringer tone, and then press **SELECT** to save.

NOTE

- If you turn off the ringer volume, you will not hear ringer tone samples.

Ringer volume

You can adjust the ringer volume level, or turn the ringer off.

- Press **MENU** when the handset is not in use.
- Scroll to **Ringers**, and then press **SELECT**.
- Press **SELECT** to choose **Ringer volume**.
- Scroll to adjust the volume, and then press **SELECT** to save.

NOTE

- If the handset ringer volume is set to off, that handset is silenced for all incoming calls except paging tone.

Temporary ringer silencing

When the telephone is ringing, you can temporarily silence the ringer of the handset without disconnecting the call. The next call rings normally at the preset volume.

- Press **OFF** or **MUTE** on the handset. The handset displays  and **Ringer muted** briefly.

Quiet mode

You can turn on the quiet mode for a period of time. During this period, all tones (except paging tone) and call screening are muted. When you turn on the quiet mode, the answering system turns on automatically.

- Press and hold** ^{ONE}**#** on the handset or telephone base when idle.
- Use the dialing keys (**0-9**) to enter the duration, and then press **SELECT** to save.

- To turn off the quiet mode, **press and hold** ^{ONE}**#** on the handset or telephone base when idle.

Expand your telephone system

You can add new handsets (**CS6709**, purchased separately) to your telephone system. Your telephone base supports a maximum of five handsets.

For more details, refer to the user's manual that comes with your **CS6709** new handset.

ECO mode

This power conserving technology reduces power consumption for optimal battery performance. The ECO mode activates automatically whenever the handset is synchronized with the telephone base.

General product care

Taking care of your telephone

Your cordless telephone contains sophisticated electronic parts, so it must be treated with care.

Avoid rough treatment

Place the handset down gently. Save the original packing materials to protect your telephone if you ever need to ship it.

Avoid water

Your telephone can be damaged if it gets wet. Do not use the handset outdoors in the rain, or handle it with wet hands. Do not install the telephone base near a sink, bathtub or shower.

Electrical storms

Electrical storms can sometimes cause power surges harmful to electronic equipment. For your own safety, take caution when using electrical appliances during storms.

Cleaning your telephone

Your telephone has a durable plastic casing that should retain its luster for many years. Clean it only with a dry non-abrasive cloth. Do not use dampened cloth or cleaning solvents of any kind.

Frequently asked questions

Below are the questions most frequently asked about the cordless telephone. If you cannot find the answer to your question, visit our website at

www.vtechphones.com or call **1 (800) 595-9511** for customer service. In Canada, go to **www.vtechcanada.com** or call **1 (800) 267-7377**.

My telephone does not work at all.	Make sure the telephone base is installed properly, and battery is installed and charged correctly. For optimum daily performance, return the handset to the telephone base after use.
The display shows No line . I cannot hear the dial tone.	Disconnect the telephone line cord from your telephone and connect it to another telephone. If there is no dial tone on that other telephone either, then the telephone line cord may be defective. Try installing a new telephone line cord. <p>If changing telephone line cord does not help, the wall jack (or the wiring to this wall jack) may be defective. Contact your telephone service provider.</p>
	You may be using a new cable or VoIP service, the existing telephone jacks in your home may no longer work. Contact your service provider for solutions.
The display shows To register HS... and ...see manual alternately. The handset does not work at all.	The handset is deregistered from the telephone base. Place the handset in the telephone base to register it back. The handset shows Registered and you hear a beep when the registration process completes. This process takes about 90 seconds to complete.
I accidentally set my LCD language to Spanish or French, and I don't know how to change it back to English.	While the handset is not in use, press MENU and then enter ✕364# to change the handset LCD language back to English.

Limited warranty

What does this limited warranty cover?

The manufacturer of this VTech Product warrants to the holder of a valid proof of purchase ("Consumer" or "you") that the Product and all accessories provided in the sales package ("Product") are free from defects in material and workmanship, pursuant to the following terms and conditions, when installed and used normally and in accordance with the Product operating instructions. This limited warranty extends only to the Consumer for Products purchased and used in the United States of America and Canada.

What will VTech do if the Product is not free from defects in materials and workmanship during the limited warranty period ("Materially Defective Product")?

During the limited warranty period, VTech's authorized service representative will repair or replace at VTech's option, without charge, a Materially Defective Product. If we repair the Product, we may use new or refurbished replacement parts. If we choose to replace the Product, we may replace it with a new or refurbished Product of the same or similar design. We will retain defective parts, modules, or equipment. Repair or replacement of the Product, at VTech's option, is your exclusive remedy. VTech will return the repaired or replacement Products to you in working condition. You should expect the repair or replacement to take approximately 30 days.

How long is the limited warranty period?

The limited warranty period for the Product extends for ONE (1) YEAR from the date of purchase. If VTech repairs or replaces a Materially Defective Product under the terms of this limited warranty, this limited warranty also applies to the repaired or replacement Product for a period of either (a) 90 days from the date the repaired or replacement Product is shipped to you or (b) the time remaining on the original one-year warranty; whichever is longer.

What is not covered by this limited warranty?

This limited warranty does not cover:

- Product that has been subjected to misuse, accident, shipping or other physical damage, improper installation, abnormal operation or handling, neglect, inundation, fire, water or other liquid intrusion; or
- Product that has been damaged due to repair, alteration or modification by anyone other than an authorized service representative of VTech; or
- Product to the extent that the problem experienced is caused by signal conditions, network reliability, or cable or antenna systems; or
- Product to the extent that the problem is caused by use with non-VTech accessories; or
- Product whose warranty/quality stickers, product

- serial number plates or electronic serial numbers have been removed, altered or rendered illegible; or
- Product purchased, used, serviced, or shipped for repair from outside the United States of America or Canada, or used for commercial or institutional purposes (including but not limited to Products used for rental purposes); or
- Product returned without a valid proof of purchase (see item 2 on the next page); or
- Charges for installation or set up, adjustment of customer controls, and installation or repair of systems outside the unit.

How do you get warranty service?

To obtain warranty service in the United States of America, please visit our website at **www.vtechphones.com** or call **1 (800) 595-9511**. In Canada, go to **www.vtechcanada.com** or dial **1 (800) 267-7377**.

NOTE: Before calling for service, please review the user's manual - a check of the Product's controls and features may save you a service call.

Except as provided by applicable law, you assume the risk of loss or damage during transit and transportation and are responsible for delivery or handling charges incurred in the transport of the Product(s) to the service location. VTech will return repaired or replaced Product under this limited warranty. Transportation, delivery or handling charges are prepaid. VTech assumes no risk for damage or loss of the Product in transit. If the Product failure is not covered by this limited warranty, or proof of purchase does not meet the terms of this limited warranty, VTech will notify you and will request that you authorize the cost of repair prior to any further repair activity. You must pay for the cost of repair and return shipping costs for the repair of Products that are not covered by this limited warranty.

What must you return with the Product to get warranty service?

- Return the entire original package and contents including the Product to the VTech service location along with a description of the malfunction or difficulty; and
- Include a "valid proof of purchase" (sales receipt) identifying the Product purchased (Product model) and the date of purchase or receipt; and
- Provide your name, complete and correct mailing address, and telephone number.

Other limitations

This warranty is the complete and exclusive agreement between you and VTech. It supersedes all other written or oral communications related to this Product. VTech provides no other warranties for this Product. The warranty exclusively describes all of VTech's responsibilities regarding the Product. There are no other express warranties. No one is authorized to make

modifications to this limited warranty and you should not rely on any such modification.

State/Provincial Law Rights: This warranty gives you specific legal rights, and you may also have other rights, which vary from state to state or province to province.

Limitations: Implied warranties, including those of fitness for a particular purpose and merchantability (an unwritten warranty that the Product is fit for ordinary use) are limited to one year from the date of purchase. Some states/provinces do not allow limitations on how long an implied warranty lasts, so the above limitation may not apply to you. In no event shall VTech be liable for any indirect, special, incidental, consequential, or similar damages (including, but not limited to lost profits or revenue, inability to use the Product or other associated equipment, the cost of substitute equipment, and claims by third parties) resulting from the use of this Product. Some states/provinces do not allow the exclusion or limitation of incidental or consequential damages, so the above limitation or exclusion may not apply to you.

Please retain your original sales receipt as proof of purchase.



Specifications are subject to change without notice. © 2018 for VTech Communications, Inc. All rights reserved. 12/18. CS6719_AC18_V8.0 Document order number: 91-007063-080-100

